

## **D1000 and D2000 SERIES SENSOR TO COMPUTER INTERFACE MODULES**

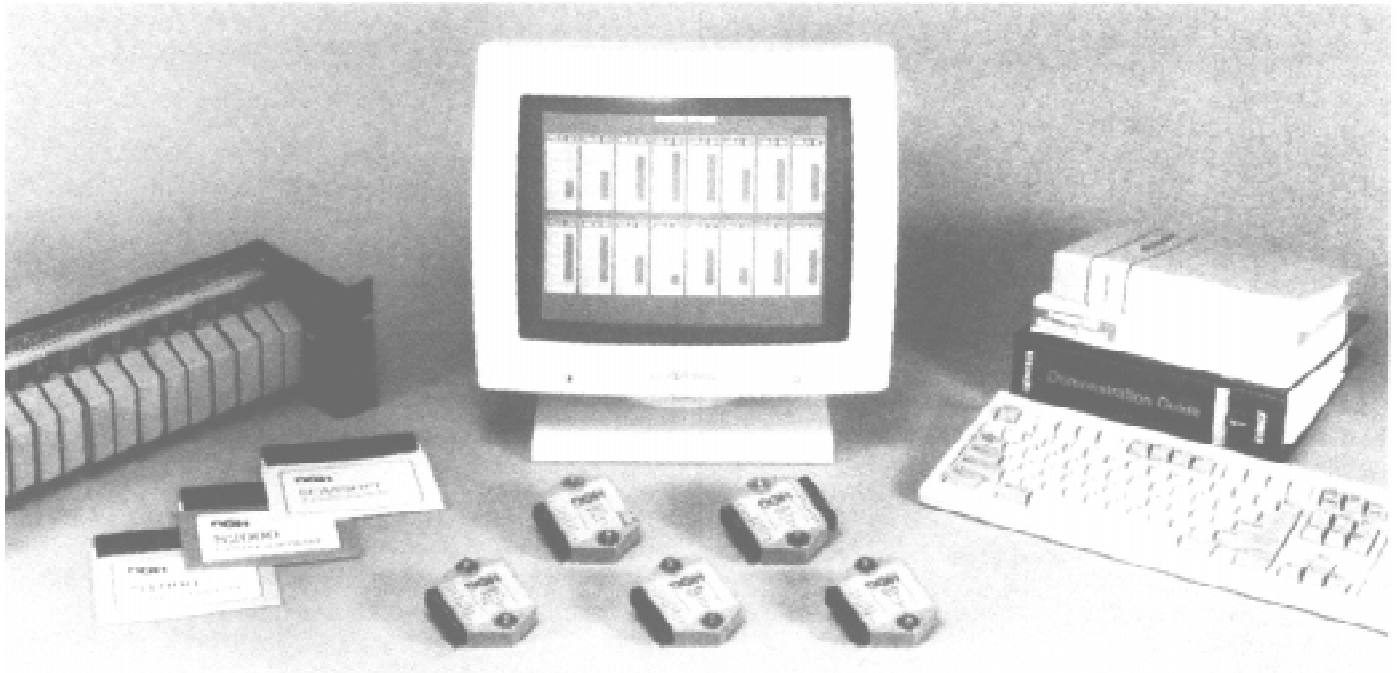

### **D1000 and D2000 FEATURES**

- Complete sensor to RS-485 or RS-232C interface.
- ASCII format command/response protocol.
- 500V rms analog input isolation.
- 15 bit measurement resolution.
- Continuous self-calibration; no adjustments of any kind.
- Programmable digital filter.
- Digital limit setting and alarm capability.
- Digital inputs and outputs connect to solid state relays.
- Events counter to 10 million.
- Requires +10V to +30Vdc unregulated supply.
- Transient suppression on RS-485 communications lines.
- Screw terminal plug connectors supplied.

### **D2000 PROGRAMMABLE FEATURES**

Provides intelligent features not found in the D1000.

- ASCII output scaled to desired engineering units.
- User programmable nonlinear transfer function.
- Straight-line segment approximation: up to 24 segments.

### **APPLICATIONS**

- Process monitoring and control
- Remote data logging to any host computer
- Product testing
- Direct connection to modems

---

## D1000 and D2000 SPECIFICATIONS (typical at +25°C and nominal power supply unless otherwise noted)

---

### Analog

- Single channel analog input.
- Maximum CMV, input to output at 60Hz: 500V rms.
- Leakage current, input to output at 115Vrms, 60Hz: <2 $\mu$ A rms.
- 15 bit measurement resolution.
- 8 conversions per second.
- Autozero & autocalibration—no adjustment pots.

### Digital

- 8-bit CMOS microcomputer.
- Digital scaling, linearization and calibration .
- Nonvolatile memory eliminates pots and switches.

### Digital filtering

- Small and large signal with user selectable time constants from 0 to 16 seconds.

### Events counter

- Up to 10 million positive transitions at 60Hz max., filtered for switch debounce.

### Digital inputs

- Voltage levels:  $\pm 30$ V without damage.
- Switching levels: High, 3.5V min., Low, 1.0V max.
- Internal pull up resistors for direct switch input.

### Digital outputs

- Open collector to 30V, 30mA max. load.

### Alarm outputs

- HI/LO limit checking by comparing input values to down-loaded HI/LO limit values stored in memory.
- Alarms: latching (stays on if input returns to within limits) or momentary (turns off if input returns to within limits).

### Communications

- Communications in ASCII via RS-232C, RS-485 ports.
- Selectable baud rates: 300, 600, 1200, 2400, 4800, 9600, 19200, 38400.
- NRZ asynchronous data format; 1 start bit, 7 data bits, 1 parity bit and 1 stop bit.
- Parity: odd, even, none.
- User selectable channel address.
- ASCII format command/response protocol.
- Up to 124 multidrop modules per host serial port.
- Communications distance up to 4,000 feet (RS-485).
- Transient suppression on RS-485 communications lines.
- Communications error checking via checksum.
- Can be used with "dumb terminal".
- Scan up to 250 channels per second.
- All communications setups stored in EEPROM.

### Power

Requirements: Unregulated +10V to +30Vdc ,  
0.75W max (D1500/D2500, 2.0W max.).  
Internal switching regulator.  
Protected against power supply reversals.

### Environmental

Temperature Range: Operating -25°C to +70°C.  
Storage -25°C to +85°C.  
Relative Humidity: 0 to 95% noncondensing.

### Warranty

12 months on workmanship and material.

---

### D1100/D2100 Voltage Inputs

- Voltages:  $\pm 10$ mV,  $\pm 100$ mV,  $\pm 1$ V,  $\pm 5$ V,  $\pm 10$ V,  $\pm 100$ Vdc.
- Resolution: 0.01% of FS (4 digits).
- Accuracy:  $\pm 0.02\%$  of FS max.
- Common mode rejection: 100dB at 50/60Hz.
- Zero drift:  $\pm 1$  count max (autozero).
- Span tempco:  $\pm 50$ ppm/ $^{\circ}$ C max.
- Input burnout protection to 250Vac .
- Input impedance:  $\leq \pm 1$ V input = 100M $\Omega$  min.  
 $\geq \pm 5$ V input = 1M $\Omega$  min.
- 1 Digital input/Event counter, 2 Digital outputs.

### D1200/D2200 Current Inputs

- Currents:  $\pm 1$ mA,  $\pm 10$ mA,  $\pm 100$ mA,  $\pm 1$ A, 4-20mAdc.
- Resolution: 0.01% of FS (4 digits), 0.04% of FS (4-20mA).
- Accuracy:  $\pm 0.02\%$  of FS, 0.04% of FS (4-20mA).
- Common mode rejection: 100dB at 50/60Hz.
- Zero drift:  $\pm 1$  count max (autozero).
- Span tempco:  $\pm 50$ ppm/ $^{\circ}$ C max. ( $\pm 1$ A =  $\pm 80$  ppm/ $^{\circ}$ C max.).
- Voltage drop:  $\pm 0.1$ V max.
- 1 Digital input/Event counter, 2 Digital outputs.

### D1300 Thermocouple Inputs

- Thermocouple types: J, K, T, E, R, S, B, C (factory set).
- Ranges: J = -200 $^{\circ}$ C to +760 $^{\circ}$ C      B = 0 $^{\circ}$ C to +1820 $^{\circ}$ C  
K = -150 $^{\circ}$ C to +1250 $^{\circ}$ C      S = 0 $^{\circ}$ C to +1750 $^{\circ}$ C  
T = -200 $^{\circ}$ C to +400 $^{\circ}$ C      R = 0 $^{\circ}$ C to +1750 $^{\circ}$ C  
E = -100 $^{\circ}$ C to +1000 $^{\circ}$ C      C = 0 $^{\circ}$ C to +2315 $^{\circ}$ C
- Resolution:  $\pm 1^{\circ}$ .
- Overall Accuracy (error from all sources) from 0 to +40 $^{\circ}$ C ambient:  $\pm 1.0^{\circ}$ C max (J, K, T, E).  
 $\pm 2.5^{\circ}$ C max (R, S, B, C)(300 $^{\circ}$ C TO FS).
- Common mode rejection: 100dB at 50/60Hz.
- Input impedance: 100M $\Omega$  min.
- Lead resistance effect: <20 $\mu$ V per 350 $\Omega$ .
- Open thermocouple indication.
- Input burnout protection to 250Vac.
- User selectable  $^{\circ}$ C or  $^{\circ}$ F.
- Overrange indication.
- Automatic cold junction compensation and linearization.
- 2 Digital inputs, Event counter, 3 Digital outputs.

### D1400 RTD Inputs

- RTD types:  $\alpha = .00385$ ,  $.00392$ , 100 $\Omega$  at 0 $^{\circ}$ C,  
 $.00388$ , 100 $\Omega$  at 25 $^{\circ}$ C.
  - Ranges:  $.00385 = -200^{\circ}$ C to +850 $^{\circ}$ C.  
 $.00392 = -200^{\circ}$ C to +600 $^{\circ}$ C.  
 $.00388 = -100^{\circ}$ C to +125 $^{\circ}$ C.
  - Resolution: 0.1 $^{\circ}$ .
  - Accuracy:  $\pm 0.3^{\circ}$ C.
  - Common mode rejection: 100dB at 50/60Hz.
  - Input connections: 2, 3, or 4 wire.
  - Excitation current: 0.25mA.
  - Lead resistance effect: 3 wire - 2.5 $^{\circ}$ C per  $\Omega$  of imbalance.  
4 wire - negligible.
  - Max lead resistance: 50 $\Omega$ .
  - Input protection to 120Vac .
  - Automatic linearization and lead compensation.
  - User selectable  $^{\circ}$ C or  $^{\circ}$ F.
  - 1 Digital output.
-

### D1450 Thermistor Inputs

- Thermistor types: 2252Ω at 25°C, TD Series
- Ranges: 2252Ω = -0°C to +100°C.  
TD = -40°C to +150°C.
- Resolution: 2252Ω = 0.01°C or F.  
TD = 0.1°C or F
- Accuracy: 2252Ω = ±0.1°C.  
TD = ±0.2°C
- Common mode rejection: 100dB at 50/60Hz.
- Input protection to 30Vdc .
- User selectable °C or °F.
- 1 Digital input/ Event counter, 2 Digital outputs.

### D1500/D2500 Bridge Inputs

- Voltage Ranges: ±30mV, ±100mV, 1-6Vdc.
- Resolution: 10μV (mV spans).  
0.02% of FS (V span).
- Accuracy: ±0.05% of FS max.
- Common mode rejection: 100dB at 50/60Hz.
- Input protection to 30Vdc .
- Offset Control: Full input range.
- Excitation Voltage: 5V, 8V, 10Vdc, 60mA max.
- Zero drift: ±1μV/°C max.
- Span tempco: ±50ppm/°C max.
- 1 Digital output.

### D1600/D2600 Timer and Frequency Inputs

- Input impedance: 1MΩ.
- Switching level: selectable 0V, +2.5V.
- Hysteresis: Adjustable 10mV-1.0V.
- Input protection: 250Vac .
- 1 Digital input/Event counter.

### Frequency Input

- Range: 1Hz to 20KHz.
- Resolution: 0.005% of reading + 0.01Hz.
- Accuracy: ±0.01% of reading ±0.01Hz.
- Tempco: ±20ppm/°C.

### Timer Input

- Range: 100μs to 30 s.
- Resolution: 0.005% of reading +10μs.
- Accuracy: ±0.01% of reading ±10μs.
- Tempco: ±20ppm/°C.

### Event Counter Input

- Input Bandwidth: 60Hz, (optional 20KHz max.).
- Up to 10 million positive transitions.

### Accumulator Input

- Input Frequency Range: 1Hz to 10KHz.
- Input Timer Range: 100μs to 30s.
- Pulse Count: Up to 10 million positive transitions.
- Resolution: 0.005% of reading +0.01Hz (Frequency).  
0.005% of reading +10μs (Timer) .
- Accuracy: ±0.01% of frequency reading ±0.01Hz.  
±0.01% of timer reading ±10μs.
- Tempco: ±20ppm/°C.

### D1700 Digital Inputs/Outputs

- D1711, D1712: 15 digital input/output bits.
- User can define any bit as an input or an output.
- Input voltage levels: 0-30V without damage.
- Input switching levels: High, 3.5V min., Low, 1.0V max.
- Outputs: Open collector to 30V, 100mA max. load.
- Vsat: 1.0V max @ 100mA.
- Single bit or parallel I/O addressing.

D1701, D1702: 7 digital inputs and 8 digital outputs.

- Input voltage levels: ±30V without damage.
- Input switching levels: High, 3.5V min., Low, 1.0V max.
- Outputs: open collector to 30V, 30mA max. load.
- Vsat: 0.2V max @ 30mA.
- Internal pull up resistors for direct switch input.
- Inputs/Outputs are read/set in parallel.

Specifications are subject to change without notice.

### Mechanicals and Dimensions

Case: ABS with captive mounting hardware.

Connectors: Screw terminal barrier plug (supplied).

Replace with Phoenix MSTB 1.5/10 ST 5.08 or equivalent.

#### D1300 Series

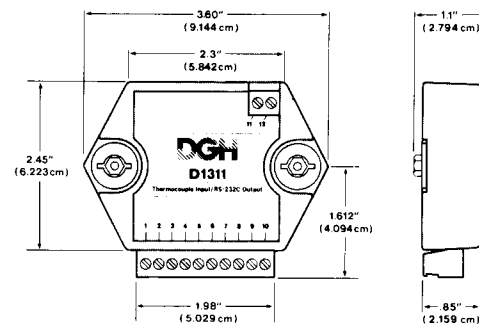

#### D1700 Series

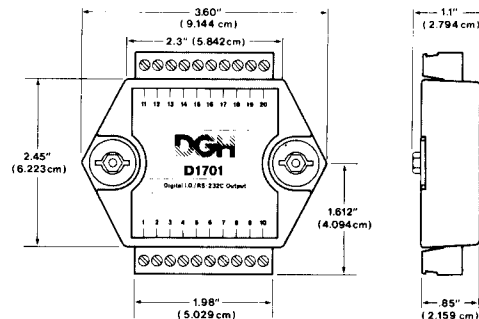

#### D1000/D2000 Series

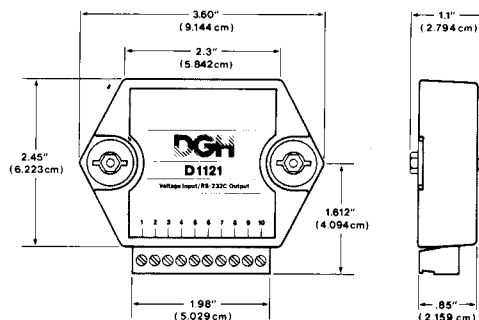

**NOTE:** Spacing for mounting screws = 2.700" (6.858 cm).  
Screw threads are 6 X 32.

---

## GENERAL DESCRIPTION

The D1000 and D2000 Sensor to Computer Modules are a family of complete solutions designed for data acquisition systems based on personal computers and other processor-based equipment with standard serial I/O ports. The modules convert analog input signals to engineering units and transmit in ASCII format to any host with standard RS-485 or RS-232C ports. These modules can measure temperature, pressure, voltage, current and various types of digital signals. The modules provide direct connection to a wide variety of sensors and perform all signal conditioning, scaling, linearization and conversion to engineering units. Each module also provides digital I/O lines for controlling devices through solid state relays or TTL signals. These digital I/O lines along with built-in limit setting capability provide alarm and control outputs.

The modules contain no pots or switches to be set. Features such as address, baud rate, parity, alarms, echo, etc. are selectable using simple commands over the communications port—without requiring access to the module. The selections are stored in nonvolatile EEPROM which maintains data even after power is removed.

The key to the DGH product concept is that the modules are easy to use. You do not need engineering experience in complicated data acquisition hardware. With the DGH modules, anyone familiar with a personal computer can construct a data acquisition system. This modular approach to data acquisition is extremely flexible, easy to use and cost effective. Data is acquired on a per channel basis so you only buy as many channels as you need. The modules can be mixed and matched to fit your application. They can be placed remote from the host and from each other. You can string up to 124 modules on one set of wires by using RS-485 with repeaters.

The D2000 series is an enhanced version of the D1000 series of sensor interfaces. The D2000 series allows the user to scale the output data in any desired engineering units. The D2000 also provides the ability to program nonlinear transfer functions. This feature may be used to linearize nonstandard sensors or to provide outputs in engineering units which are nonlinear functions of the input.

The D2000 can be programmed to approximate square law, root, log, high-order polynomial or any other nonlinear function. The D2000 may also be empirically field-programmed when the exact transfer function is unknown.

The D1000 and D2000 modules are isolated data acquisition systems for real-time distributed processing and control. By distributing computer power to each sensor location, the host computer is unburdened from interpreting data from sensor inputs. Instead of scaling and linearizing sensor data, the host computer can be used

more efficiently to scan a greater number of inputs and to provide faster control output.

The D1000 and D2000 are compatible with the DGH D3000 and D4000 series and may be mixed in any combination. The D3000 and D4000 series convert ASCII format input commands to voltage or current output signals.

All modules are supplied with screw terminal plug connectors and captive mounting hardware. The connectors allow system expansion, reconfiguration or repair without disturbing field wiring. Their small size allows them to be mounted in virtually any location or position including explosion-proof housings and DIN rails.

Although software is not required, utility software (S1000) is available on IBM-compatible diskette from DGH to make the D1000 easier to learn and use. S1000 software is provided at no charge on request with a purchase order and is not copy protected.

## THEORY OF OPERATION

Each DGH module is a complete single-channel data acquisition system. Each unit contains analog signal conditioning circuits optimized for a specific input type. The amplified sensor signals are converted to digital data with a microprocessor-controlled integrating A/D converter. Offset and gain errors in the analog circuitry are continuously monitored and corrected using microprocessor techniques. The D1000 converts the digital signal data into engineering units using look-up tables. The D2000 converts the digital signal data into engineering units using look-up tables that are customer-programmed. The resultant data is stored in ASCII format in a memory buffer. The modules continuously convert data at the rate of 8 conversions per second and store the latest result in the buffer. The host computer may request data by sending simple ASCII commands to the module. The D1000 will then instantly respond by communicating the ASCII buffer data back to the host. Up to 124 modules may be linked to a single RS-232C or RS-485 host computer port. Each module on a serial line is identified by a unique user-programmable address. This addressing technique allows modules to be interrogated in any order.

## DIGITAL INPUTS/OUTPUTS

D1000 and D2000 modules also contain up to three digital outputs and two digital inputs. The digital outputs are open-collector transistor switches that may be controlled by the host computer. These switches may be used to control solid-state relays which in turn may control heaters, pumps and other power equipment. The digital inputs may be read by the host computer and used to sense the state of a remote digital signals. They are ideal for sensing the state of limit or safety switches. Digital I/O capability may be expanded by using the DGH D1700 modules.

## EVENT COUNTER

With the exception of D1400 RTD, D1500 and D2500 bridge input modules, every module contains an onboard event counter. The event counter will count up to 10 million transitions that occur on the digital input. The event counter may be read and cleared by the host computer at any time. The counter has many applications where a host computer must read an accumulated count of events. It may be used in production line applications to keep a record of repetitious operations. For applications that only require counting, DGH offers the D1621 and D1622 Event Counter modules. These modules have no analog input but count events up to 10 million at either 60Hz or 20KHz bandwidths.

For applications that require reading and accumulating pulse-type information DGH offers the Accumulator modules. The Accumulators can read both the rate and the total count of a frequency or pulse input signal. They can keep track of power consumption when connected to a power meter or accumulate the output of pulse-type flow meters.

## ALARM OUTPUTS

The D1000 and D2000 modules include digital high and low alarm functions. High and low alarm limits may be downloaded into the module by the host computer. The limit data is compared against the analog input data after every A/D conversion. The result of the limit comparison may be read by the host. The high and low limits may also be used to control the digital outputs on the module. The limits may be used to turn on alarms or to shut down a process independent of a host computer. Limit data may be changed at any time with commands from the host computer. Limit values are stored in nonvolatile memory to preserve the values even when module power is removed. Limit data is downloaded in the same engineering units as output data. Alarm outputs may be programmed to be latching to record the occurrence of a single alarm event. Alarm outputs may also be configured to form simple on-off controllers that are independent of the host computer.

## USER OPTIONS

To provide maximum flexibility, the D1000 and D2000 offer a variety of user-selectable options including choice of address, baud rate, parity, alarm options, echo, etc. All options are selectable using simple commands over the communications port. All option selections are stored in a nonvolatile EEPROM which maintains data even after power is removed. The modules contain no pots or switches to be set. All options may be changed remotely without requiring access to the module.

## DIGITAL FILTER

The D1000 and D2000 options include a unique programmable single pole digital filter. The filter is used to smooth analog data in noisy environments. Separate time constants may be specified for small and large signal changes. Typically a large time constant is specified for small signal changes to filter out noise and provide stable

output readings. A smaller time constant may be chosen for large signal changes to provide fast response to such changes.

## COMMUNICATIONS

The D1000 and D2000 are designed to be easy to interface to all popular computers and terminals. All communications to and from the module are performed with printable ASCII characters. This allows the information to be processed with string functions common to most high-level languages such as BASIC. For computers that support standard ports such as RS-232C, no special machine language software drivers are necessary for operation. The modules can also be connected to auto-answer modems for long-distance operation without the need for a remote supervisory computer. The ASCII format makes system debugging easy with a dumb terminal.

RS-232C is the most widely used communications standard for information transfer between computing equipment. RS-232C versions of the D1000 and D2000 will interface to virtually any computer without additional hardware. RS-232C is not designed to be used as a multiparty system; however the modules can be daisy-chained, as shown in figure 1, to allow many modules to be connected to a single communications port. In this network, any characters transmitted by the host are received by each module in the chain and passed on to the next station until the information is echoed back to the host. In this way all commands given by the host are examined by every module in the chain. If a module is correctly addressed and receives a valid command, it transmits a response on the daisy chain network. The response will be rippled through any other modules in the chain until it reaches the host.

RS-485 is a communications standard developed for multidropped systems that can communicate at high data rates over long distances, as shown in figure 2. RS-485 is similar to RS-422 in that it uses a balanced differential pair of wires switching from 0 to 5V to communicate data. RS-485 receivers can handle common mode voltages from -7

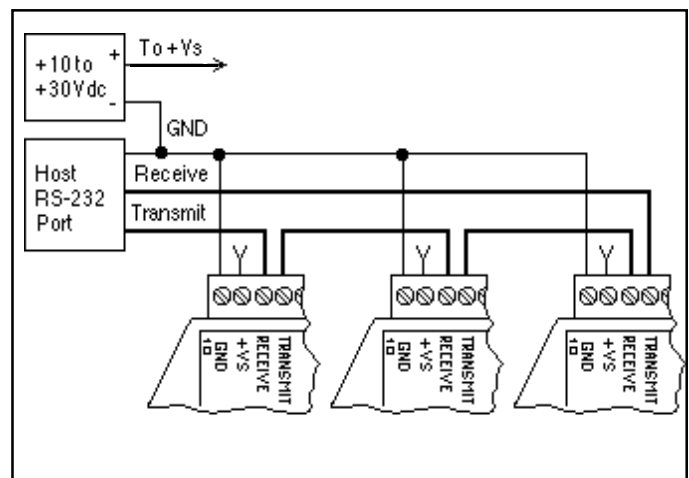

Figure 1 RS-232 Daisy Chain Network.

to +12V without loss of data, making them ideal for transmission over great distances. RS-485 differs from RS-422 by using one balanced pair of wires for both transmitting and receiving. Since an RS-485 system cannot transmit and receive at the same time it is a half-duplex system. For systems requiring many modules, high speed or long wiring distances the RS-485 standard is recommended.

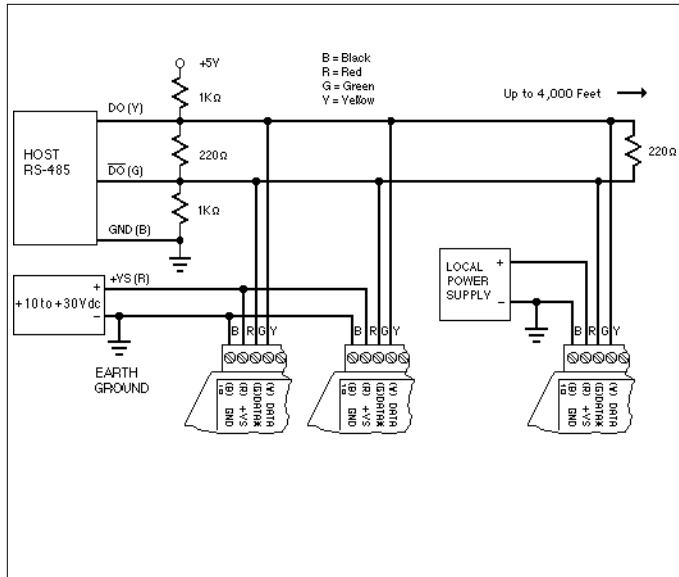

Figure 2. RS-485 Multidrop Network.

## COMMAND SET

All DGH products use a simple command/response protocol for communication. A module must be interrogated by the host to obtain data. A module can never initiate a command sequence. A typical command/response sequence could look like this:

*Command:* \$1RD  
*Response:* \*+00075.00

A command is initiated with a command prompt, which may be a dollar sign (\$) or a pound sign (#). Following the prompt a single address character must be transmitted. Each module on a communications bus must be setup with a unique address. The command is directed in this case to module address '1'. The address is followed by a two-character command which in this case is RD for Read Data. The command is terminated with a carriage return.

After module address '1' receives the command it will respond with the analog input data. The response begins with a response prompt, which is an asterisk (\*). The data is read back in a standardized format of sign, 5 digits, decimal point, and 2 more digits. All DGH modules represent data in the same standard format.

Table 1 shows all the D1000 and D2000 commands. For each case, a sample command and response is shown. Notice that some commands only respond with an \* acknowledgment.

Table 1. D1000 and D2000 Series Command Set.

Command and Definition	Typical Command Message (\$ prompt)	Typical Response Message
DI Read Alarms/Digital Inputs	\$1DI	*0003
DO Set Digital Outputs	\$1DOFF	*
ND New Data	\$1ND	*+00072.00
RD Read Data	\$1RD	*+00072.00
RE Read Event Counter	\$1RE	*0000107
RL Read Low Alarm Value	\$1RL	*+00000.00 L
RH Read High Alarm Value	\$1RH	*+00510.00 L
RS Read Setup	\$1RS	*31070142
RZ Read Zero	\$1RZ	*+00000.00
WE Write Enable	\$1WE	*

## Write Protected Commands.

CA Clear Alarms	\$1CA	*
CE Clear Events	\$1CE	*
CZ Clear Zero	\$1CZ	*
DA Disable Alarms	\$1DA	*
EA Enable Alarms	\$1EA	*
EC Events Clear	\$1EC	*0000107
HI Set High Alarm Limit	\$1HI+12345.67L	*
LO Set Low Alarm Limit	\$1LO+12345.67L	*
RR Remote Reset	\$1RR	*
SU Setup Module	\$1SU31070142	*
SP Set Setpoint	\$1SP+00600.00	*
TS Trim Span	\$1TS+00600.00	*
TZ Trim Zero	\$1TZ+00000.00	*

## D2000 Programming Commands (Write Protected).

BP Set Breakpoint	\$1BP00-00200.00	*
EB Erase Breakpoint Table	\$1EB	*
MN Set Minimum Value	\$1MN-00200.00	*
MX Set Maximum Value	\$1MX+00750.00	*

For greater data security, options are available to echo transmitted commands and to send and receive checksums. The # command prompt requests a response message from the module that begins with an \*, followed by the channel address, command, data (if necessary) and checksum. This response echoes the channel address and command for verification and adds checksum for error checking. Checksum is a two character hexadecimal value that can be added to the end of any command message, regardless of prompt, at your option. Checksum verifies that the message received is exactly the same as the message sent.

The DGH modules perform extensive error checking on commands and will respond with an error message if necessary. For example:

*Command:* \$1AB  
*Response:* ?1 COMMAND ERROR

All error messages start with an error prompt (?) followed by the channel address and error description. In this case, the module did not recognize 'AB' as a valid command.

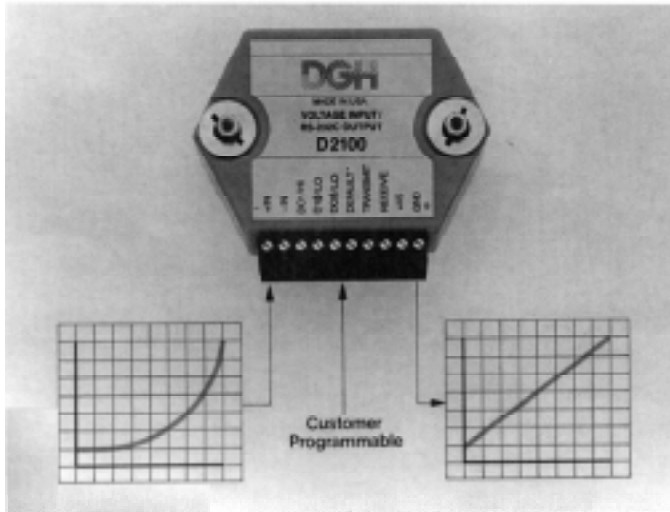

### D2000 PROGRAMMING

The outstanding feature of the D2000 series is its user-programmable output scaling. The transfer function from analog input to data output may be specified to an infinite spectrum of functions, both linear and nonlinear. Sensor data may be scaled to any desired engineering units for easy interpretation.

The D2000 uses a piece-wise linear technique to approximate nonlinear functions. Figure 3 shows this technique. The first step in programming a function is to establish the functions endpoints, as shown in figure 3a. This is accomplished by using the Minimum (MN) and Maximum (MX) commands. In cases where only linear scaling is necessary, the programming task is now complete. For nonlinear functions, the linear curve may be broken into segments by describing a breakpoint using the BreakPoint (BP) command. The breakpoint establishes an intersection between two linear segments. Figures 3b & 3c show the effect of breakpoints.

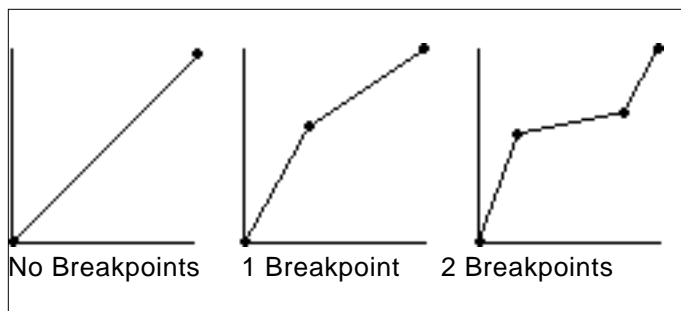

Figure 5. Piece-wise linear technique.

Up to 23 breakpoints are available to define 24 linear segments. Only two restrictions apply to the shape of the programmed transfer function:

1. The output data value must be a single-valued function of the input.
2. The output values must lie between the limits set by the endpoints.

In general, breakpoints are defined by applying a known analog signal to the input of the module. This establishes the x-axis position of the breakpoint. The y-axis position is defined in the argument of the breakpoint (BP) command. The breakpoint data is stored in nonvolatile EEPROM. The transfer function may be reprogrammed many times.

### RESOLUTION

All DGH modules represent data in the same fixed format of sign, five digits, decimal point, and two more digits; +00100.00 for example. The user can structure the D2000 output data for the best compromise between resolution and readability. For example, a +0.05 volt output indication may be structured in three output formats:

Input Voltage	Output Format	Resolution
+0.05Volts	+00000.05	5
+50 millivolts	+00050.00	5,000
+50,000 microvolts	+50000.00	5,000,000

The microvolt output format extracts the best resolution but the output data will tend to be noisy. For a 0 to 0.05V output, millivolts is the best output format choice. This gives 5,000 counts of resolution in easy to interpret units. In a typical application a D2000 module is used to output data in units of specific gravity. The specific gravity output range is between 0.5 and 2. If the output data format range is +0000.50 to +00002.00 there are only 150 counts of resolution between the minimum and maximum outputs. However, since the specific gravity of water is defined to be 1, the output may be scaled in percent. The specific gravity of water becomes 100 %. The output data range in % is from +00050.00 to +00200.00. This format allows up to 15,000 counts of resolution in easily interpreted units.

### D2000 SCALING

The D2000 can output data in easy-to-understand engineering units that may be instantly read and interpreted, without data conversion, by a host computer. For example, a pressure sensor provides a 1 to 5V linear output for pressures of 0 to 1000 psi. A D2131 reads the sensor output in millivolts. But the real parameter of interest is pressure, not voltage, and voltage readings may be difficult to interpret. To make the output data more meaningful, program the D2131 output in psi:

Pressure (psi)	Sensor Output	D2131 Output (mV)	D2131 Output (psi)
0	1.0V	+01000.00	+00000.00
500	3.0V	+03000.00	+00500.00
1000	5.0V	+05000.00	+01000.00

In many cases, the desired output data is specific to an application. Assume that the same pressure sensor is used to measure the "fullness" of a pressure vessel, such as a cylinder of compressed air. The output units could be

in units of "percent" and in this case we will assume that if the cylinder reads 750 psi it is 100% full:

Pressure (psi)	Sensor Output	D2131 Output (%)
0	1.0V	+00000.00
375	2.5V	+00050.00
750	4.0V	+00100.00

The real power of the D2000 is their ability to provide output data in engineering units for nonlinear sensors. A nonlinear transfer function may be programmed into a D2000 module by approximating the curve with a series of linear segments, using the Break Point (BP) command. A Break Point specifies the intersection between two linear segments. Up to 23 Break Points may be used to specify 24 linear segments in a curve.

The following example uses a D2131 to linearize the output of a pyrometer that uses an infrared temperature sensor. The infrared temperature sensor is inherently nonlinear and its output ranges from 0.717 to 1.406V for a temperature span of 600 to 1600°C.

Breakpoint	Input Voltage	Output Value
Minimum	+00717.00	+00600.00
00	+00844.00	+00700.00
01	+00948.00	+00800.00
02	+01036.00	+00900.00
03	+01110.00	+01000.00
04	+01174.00	+01100.00
05	+01230.00	+01200.00
06	+01280.00	+01300.00
07	+01325.00	+01400.00
08	+01367.00	+01500.00
Maximum	+01406.00	+01600.00

### Scaling a nonlinear transfer function in the field

Assume that a water tower with an irregular shape is 30 feet tall and holds about 10,000 gallons. A pressure sensor may be used to measure the height of the water in the tower. The pressure sensor produces 0.1V per foot of water starting at 0V. To create a nonlinear function in the module, the endpoints must be set first. The minimum value is known and may be programmed by applying 0V to the module corresponding to 0 gallons. A "dummy" maximum value, which we know can never be exceeded, may be used to specify the maximum endpoint. In this case we apply +5V to the module and program the maximum value to be 15,000 gallons. Starting with an empty tower, read the pressure at fixed known volumes of water, every 1000 gallons for example, and set breakpoints in the module corresponding to known amounts of water in the tower. Once the curve is programmed, the module converts the pressure signal to gallons.

The preceding example shows that D2000 modules may be programmed in the field to specific test inputs where the actual nonlinearity is unknown. Since all programming

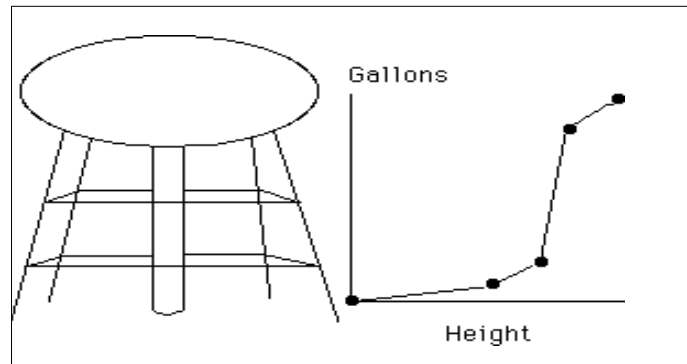

Figure 4. Scaling when the exact transfer function is unknown

is done through the communications port, access to a module is not necessary and ranging may be done remotely.

### Scaling to desired engineering units

The D2000 allows you to scale an input to desired engineering units. For example, many sensor output signals are transmitted as 4 to 20mA signals. The following example demonstrates scaling a 4 to 20mA signal to 0 to 100% using a DGH D2251 or D2252 module. The actual input range of these modules is 0 to 25mA to make it easier to adjust for zero and span and to allow for drift in the end points of the input.

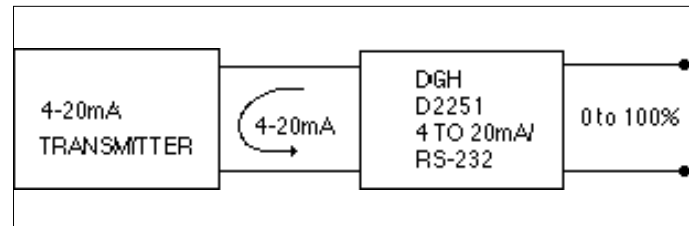

Figure 5. Scaling to desired engineering units

Since the input range 0 to 25mA and you want to use a portion of that range, you must determine the new minimum and maximum values. The two desired values: 4mA, 0% and 20mA, 100% determines the desired transfer function. Extrapolate this function to the full-scale range of the module, which is 0-25mA. This results in endpoints at 0mA, -25% and 25mA, 131.25%.

Input the new minimum and maximum values with the following procedure. In these steps, we assume a channel address of 1.

1. Connect module to computer, or terminal and establish communications.
2. Apply 0mA to the input.
3. Send a Write Enable command, \$1WE, followed by a Minimum Value command, \$1MN-00025.00. The response to both commands should be an \*.
4. Apply +25mA to the input.
5. Send a \$1WE command followed by a Maximum Value command, \$1MX+00131.25. The response to both commands should be an \*.

The entire range is rescaled and all values are read in percent.



## S1000 UTILITY SOFTWARE

The S1000 utility software diskette contains executable programs that make the D1000 series easier to learn and use. The executable programs can be run on IBM PC/XT/AT or compatible computers. An executable menu-driven setup program is provided to simplify configuration of all user-selectable options such as address, baud rate, parity. Context-sensitive help is available during configuration for each selectable parameter.

```
10 ' Display Program Menu
20 CLS:PRINT"1 Log Data":PRINT"2 Print File"
30 PRINT"3 End program":INPUT"Enter Selection : ";IN$
40 ON VAL(IN$) GOTO 70,380,50
50 END
60 'Read and store module data
70 CLS:INPUT"Input Module address ";ADDRESS$:C$=" "+ADDRESS$
90 PRINT:INPUT"Name of Disk file to store data ";NAM$
110 PRINT:INPUT"Number of Samples to take ";X
130 CLS:OPEN "com1:300,n,8,1,rs,cs,cd,ds" AS #1
140 OPEN NAM$ FOR OUTPUT AS #2
160 FOR SAMPLE = 1 TO X:GOSUB 260:NEXT
220 CLOSE #1:CLOSE #2:GOTO 20
240 ' print command to module and receive data
260 PRINT #1,C$:RESPONSE$=""
265 T=0
270 T=T+1:IF T=450 THEN RESPONSE$="Timeout":goto 330
280 IF EOF(1) THEN GOTO 270 ELSE IN$=INPUT$(1,#1)
300 IF IN$="*" OR IN$="?" THEN GOTO 310 ELSE GOTO 265
310 IN$=INPUT$(1,#1):RESPONSE$=RESPONSE$+IN$
320 IF IN$<>CHR$(13) THEN GOTO 310 ELSE LOCATE 10,1
330 PRINT"Reading for Sample";SAMPLE;" = ";+RESPONSE$
345 PRINT#2,RESPONSE$:LOCATE 5,48:PRINT " ";:RETURN
360 'Get disk file name,display file information
380 CLS:PRINT:INPUT"Disk file name to print: ";NAM$
400 OPEN NAM$ FOR INPUT AS #2
420 IF EOF(2) THEN CLOSE #2:GOTO 450
440 INPUT #2,DAT$:PRINT DAT$:GOTO 420
450 PRINT:PRINT"Press any key for main menu ..";
460 IN$=INKEY$:IF IN$<>" " THEN GOTO 20 ELSE GOTO 460
```

The S1000 also contains programming examples written in high level languages such as BASIC, TURBO PASCAL and TURBO C. The examples are easily configured for either COM1: or COM2: ports and are provided in ASCII text format. A dumb terminal program is provided for diagnosis and system debugging. The S1000 is provided at no charge on request with a purchase order and is not copy protected.

This program allows the user to log data from a module. The data will be printed to the screen as well as stored to disk in a file specified by the user. The program will prompt the user for:

1. Correct module address.
2. Name of disk file to store module response data.
3. Number of samples to request from module and store to disk.

After all readings are taken and back to the main menu, contents of the disk can be printed to the screen by selecting "Print File" option from the main menu.

The S1000 utility software can rescale and reprogram a D2000 module. Reprogramming provides menus to load, save, print, create and edit custom breakpoint tables. Rescaling and reprogramming can be done with or without an input excitation source. The program performs linear rescaling in two ways; by entering new minimum and maximum values to the program which computes the new values and sends them to the module, or by entering two points on the existing module transfer function to the program which calculates the new minimum and maximum values as shown below.

The S1000 allows the user to save the factory calibration before making any changes to a module. Store/refresh

stores a module's factory calibration to disk or restores factory calibration from disk to a module.

The S1000 also provides system configuration and setup functions. System configuration selects baud rate, parity, communications port and assigns the disk drive. Setup allows the user to select address, communications parameters, signal conditioning parameters and alarm status in a simple menu driven format.

The utility software also provides a terminal mode that can communicate directly with a module. Terminal mode operates in two ways; either by entering a command and receiving a response or by continuously requesting data (continuous mode).

```
Model = 2251 Old Minimum = +00000.00 Old Maximum = +00025.00
```

```
Calibration point A Calibration point B
```

```
Excitation in mA : +00004.00 Excitation in mA : +00020.00
New Display value : +00000.00 New Display value : +00100.00
New Minimum value = -00025.00 New Maximum value = +00131.25
```

```
Send new values to Module (y/n/<ESC> for menu)?
```

---

## DATA LOGGING SOFTWARE

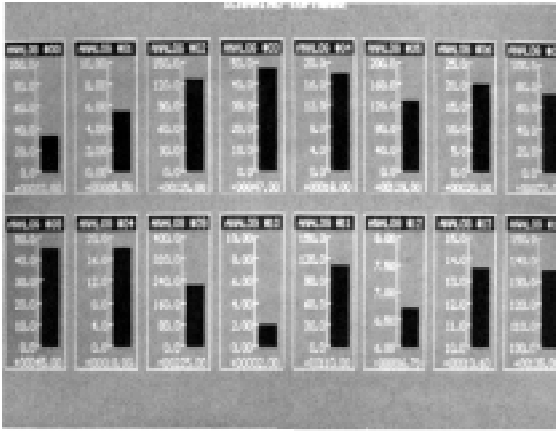

DGH Scanning Software is a menu-driven program that acquires data from D1000 and D2000 series modules. The program uses menus to configure up to 64 analog inputs and 24 digital inputs. The acquired data is displayed as text or graphically using bar or trend graphs. The software is provided at no charge on request with a purchase order and is not copy protected.

### Features

- Menu-driven (IBM-PC/XT/AT & Compatibles).
- Scan and display up to 64 D1000/2000 modules.
- Scan and display up to 24 digital inputs.
- Real time display of acquired data.
- Bargraph, trend and text displays.
- Label channels— Boiler Room, Furnace, etc.
- Save & recall system & module setups.
- Selectable module scan rate.
- Selectable log to printer rate.
- Selectable log data to disk rate.
- Selectable alarm notification to printer.
- Supported display types: VGA, CGA, EGA, Hercules.

Menus are used to set-up the modules for a data acquisition run, control start-up, data rates, display and log data to a printer. Each channel has a set-up screen status that allows you to specify your data acquisition hardware, and software options.

---

## PROCESS CONTROL SOFTWARE

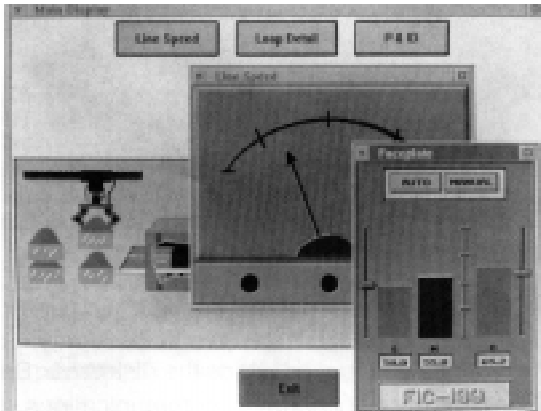

Software device drivers for DGH modules are available for icon-driven process control software such as Paragon TNT from Intech Corporation and Genesis from Iconics Corporation. These programs operate on IBM and compatible personal computers and use high resolution graphics to illustrate process control strategies. Working in a CAD environment, these software packages transform a PC into a workstation for design, testing and implementing real-time process monitoring and control strategies without programming experience. Control algorithms such as PID, alarm management, real time and historical trending and system security via password are available in each package.

Sources for commercial software device drivers:

- |                     |  |
|---------------------|--|
| PARAGON             | INTEC CONTROLS<br>55 West Street<br>Walpole, MA 02081<br>Phone: 508-660-1221                             |
| GENESIS             | ICONICS<br>100 Foxborough Boulevard<br>Foxborough, MA 02035<br>Phone: 508-543-8600                       |
| LABTECH<br>NOTEBOOK | Laboratory Technologies Corp.<br>400 Research Drive<br>Wilmington, MA 01887<br>Phone: 508-657-5400       |
| INSTATREND          | DIANACHART, Inc.<br>101 Round Hill Drive<br>Rockaway, NJ 07866<br>Phone: 201-625-2299                    |
| AIMAX-PLUS          | TA ENGINEERING CO. , INC.<br>1605 School Street<br>PO Box 186<br>Moraga, CA 94556<br>Phone: 415-376-8500 |
| PACX                | Automated Control Systems, Inc.<br>PO Box 49<br>Provo, UT 84603<br>Phone: 801-373-0678                   |

## BP-8 and BP-14 8 and 14 CHANNEL MOUNTING BACKPLANES

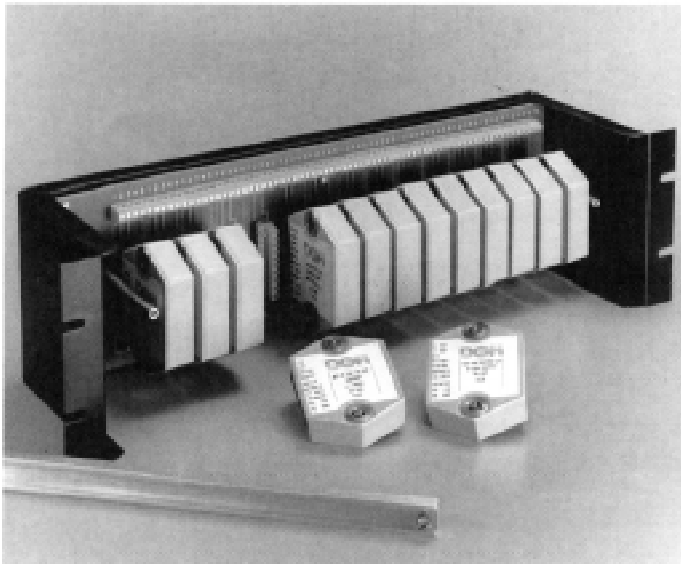

(Bracket not supplied)

The BP-8 and BP-14 are 8 and 14 channel mounting backplanes for DGH modules. The backplanes accept any RS-485 DGH analog input or analog output modules and are designed to be mounted in standard 19 inch racks. RS-485 modules are used because RS-485 is the preferred communications standard for high channel count applications. Although analog modules are used it must be noted that every DGH module has some digital I/O capability. Therefore the combination of DGH modules with the backplanes make a cost effective high density remote analog and digital data acquisition system.

The BP-8 and BP-14 reduce wiring costs by providing all common connections on the backplane. Each backplane includes screw terminals for all inputs, outputs, power connections and communications signals. The backplanes also include swaged thru-hole stand-offs for mounting, a hold-down bar, and holes for an RS-485 termination resistor.

### BP-8 DIMENSIONS

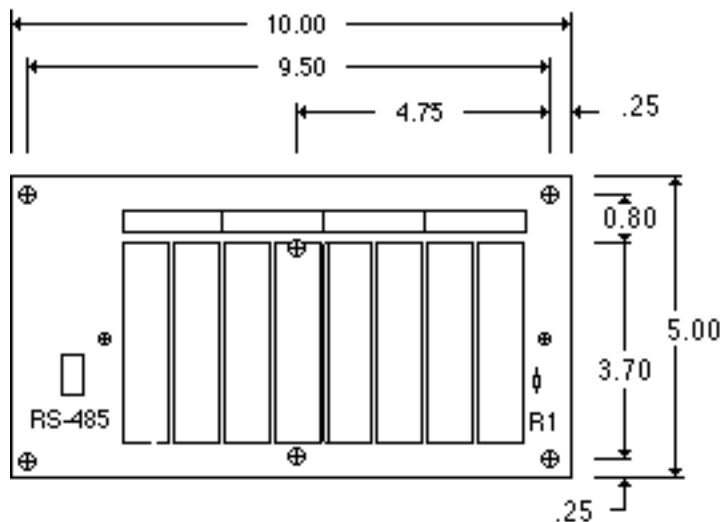

### SIDE VIEW

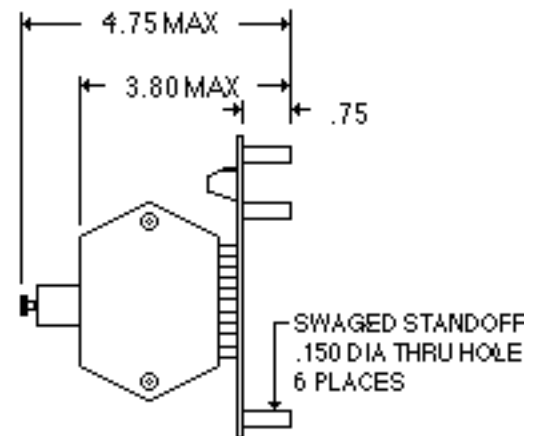

### BP-14 DIMENSIONS

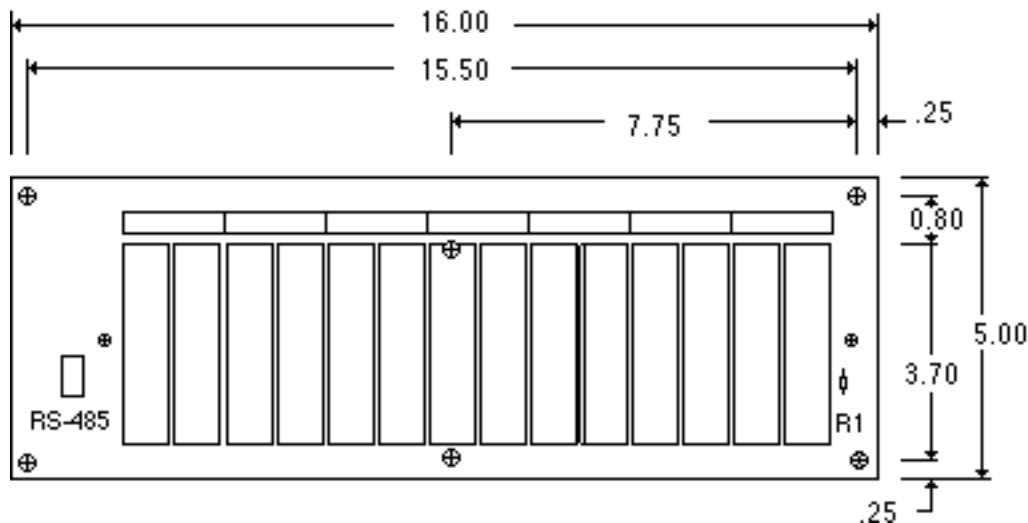

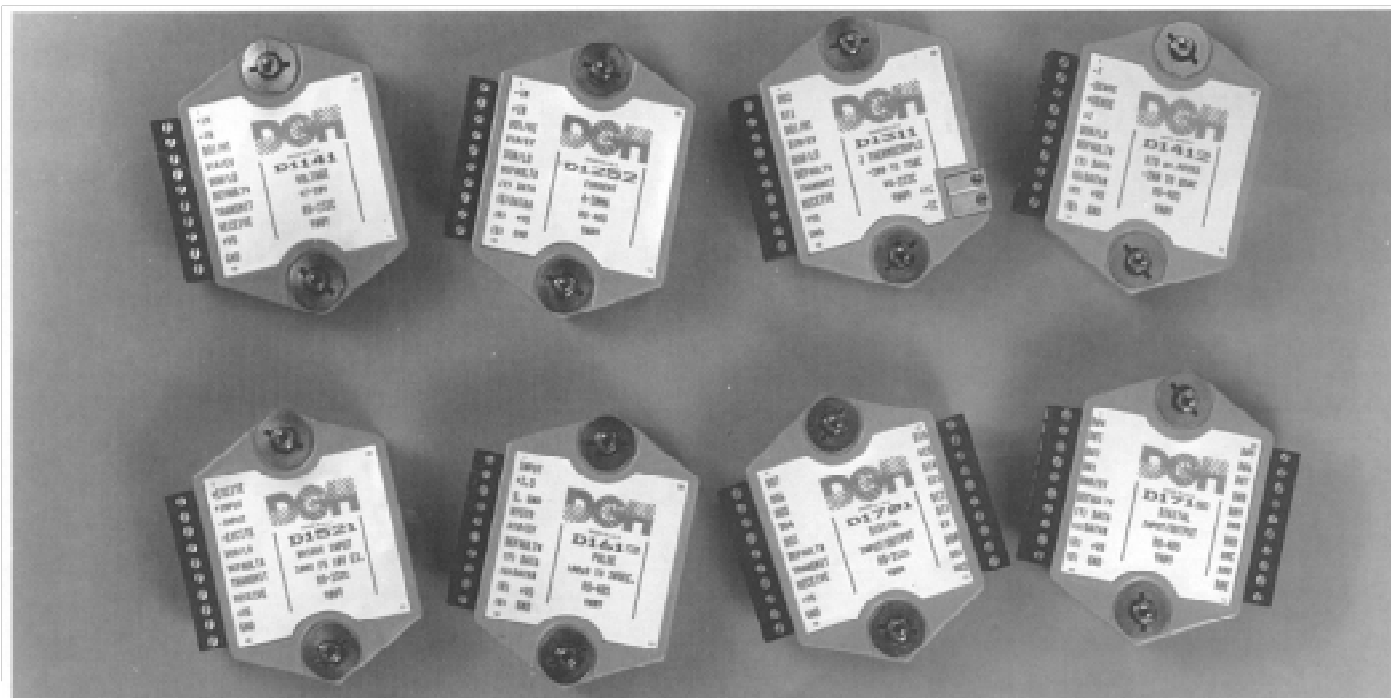

## ORDERING GUIDE

### MODEL INPUT/OUTPUT

#### Voltage Input

D1101/D2101	10mV Input/RS-232C Output
D1102/D2102	10mV Input/RS-485 Output
D1111/D2111	100mV Input/RS-232C Output
D1112/D2112	100mV Input/RS-485 Output
D1121/D2121	1V Input/RS-232C Output
D1122/D2122	1V Input/RS-485 Output
D1131/D2131	5V Input/RS-232C Output
D1132/D2132	5V Input/RS-485 Output
D1141/D2141	10V Input/RS-232C Output
D1142/D2142	10V Input/RS-485 Output
D1151/D2151	100V Input/RS-232C Output
D1152/D2152	100V Input/RS-485 Output

#### Current Inputs

D1211/D2211	10mA Input/RS-232C Output
D1212/D2212	10mA Input/RS-485 Output
D1221/D2221	1mA Input/RS-232C Output
D1222/D2222	1mA Input/RS-485 Output
D1231/D2231	100mA Input/RS-232C Output
D1232/D2232	100mA Input/RS-485 Output
D1241/D2241	1A Input/RS-232C Output
D1242/D2242	1A Input/RS-485 Output
D1251/D2251	4-20mA Input/RS-232C Output
D1252/D2252	4-20mA Input/RS-485 Output

#### Thermocouple Inputs

D1311	J Thermocouple Input/RS-232C Output
D1312	J Thermocouple Input/RS-485 Output
D1321	K Thermocouple Input/RS-232C Output
D1322	K Thermocouple Input/RS-485 Output
D1331	T Thermocouple Input/RS-232C Output
D1332	T Thermocouple Input/RS-485 Output
D1341	E Thermocouple Input/RS-232C Output
D1342	E Thermocouple Input/RS-485 Output
D1351	R Thermocouple Input/RS-232C Output
D1352	R Thermocouple Input/RS-485 Output
D1361	S Thermocouple Input/RS-232C Output
D1362	S Thermocouple Input/RS-485 Output
D1371	B Thermocouple Input/RS-232C Output
D1372	B Thermocouple Input/RS-485 Output
D1381	C Thermocouple Input/RS-232C Output
D1382	C Thermocouple Input/RS-485 Output

### MODEL INPUT/OUTPUT

#### RTD Inputs

D1411	.00385 RTD Input/RS-232C Output
D1412	.00385 RTD Input/RS-485 Output
D1421	.00392 RTD Input/RS-232C Output
D1422	.00392 RTD Input/RS-485 Output
D1431	.00388 RTD Input/RS-232C Output
D1432	.00388 RTD Input/RS-485 Output
D1451	2252Ω Thermistor Input/RS-232C Output
D1452	2252Ω Thermistor Input/RS-485 Output
D1461	TD Thermistor Input/RS-232C Output
D1462	TD Thermistor Input/RS-485 Output

#### Bridge Inputs

D1511/D2511	30mV Bridge Input, 5V Excitation/RS-232C Output
D1512/D2512	30mV Bridge Input, 5V Excitation/RS-485 Output
D1521/D2521	30mV Bridge Input, 10V Excitation/RS-232C Output
D1522/D2522	30mV Bridge Input, 10V Excitation/RS-485 Output
D1531/D2531	100mV Bridge Input, 5V Excitation/RS-232C Output
D1532/D2532	100mV Bridge Input, 5V Excitation/RS-485 Output
D1541/D2541	100mV Bridge Input, 10V Excitation/RS-232C Output
D1542/D2542	100mV Bridge Input, 10V Excitation/RS-485 Output
D1551/D2551	1-6V Bridge Input, 8V Excitation/RS-232C Output
D1552/D2552	1-6V Bridge Input, 8V Excitation/RS-485 Output
D1561/D2561	1-6V Bridge Input, 10V Excitation/RS-232C Output
D1562/D2562	1-6V Bridge Input, 10V Excitation/RS-485 Output

#### Timer and Frequency Inputs

D1601/D2601	Frequency Input/RS-232C Output
D1602/D2602	Frequency Input/RS-485 Output
D1611/D2611	Timer Input/RS-232C Output
D1612/D2612	Timer Input/RS-485 Output
D1621	Event Counter/RS-232C Output
D1622	Event Counter/RS-485 Output
D1631/D2631	Accumulator, Frequency Input/RS-232C Output
D1632/D2632	Accumulator, Frequency Input/RS-485 Output
D1641/D2641	Accumulator, Timer Input/RS-232C Output
D1642/D2642	Accumulator, Timer Input/RS-485 Output

#### Digital Inputs/Outputs

D1701	7 Digital Inputs, 8 Digital Outputs/RS-232C Output
D1702	7 Digital Inputs, 8 Digital Outputs/RS-485 Output
D1711	15 Digital Inputs and/or Outputs/RS-232C Output
D1712	15 Digital Inputs and/or Outputs/RS-485 Output



## DIN-100 SERIES SENSOR TO COMPUTER INTERFACE MODULES

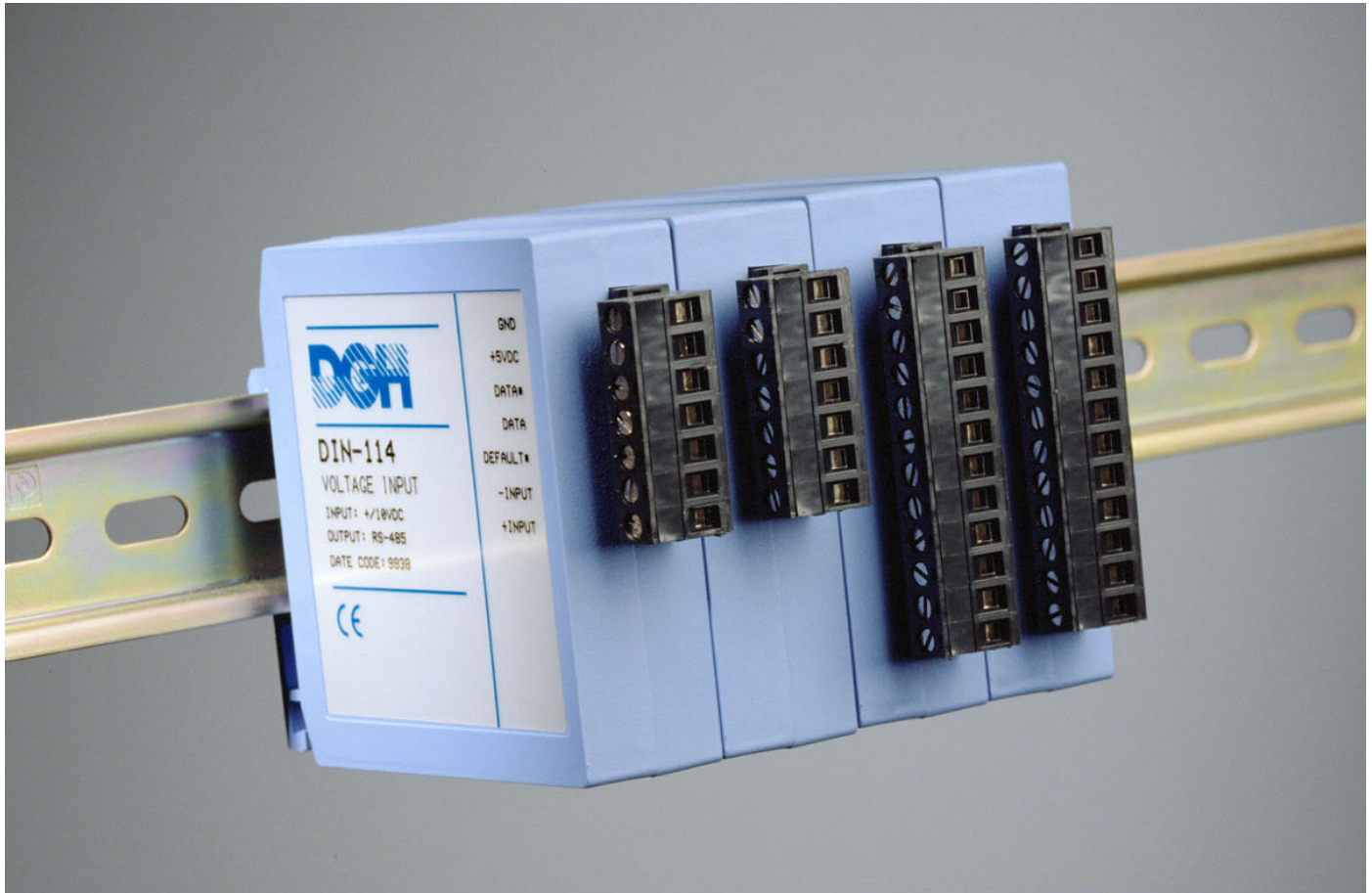

### DIN-100 FEATURES

- Complete sensor to RS-485 interface.
- 500V rms analog input isolation.
- 15 bit measurement resolution.
- Continuous self-calibration; no adjustments of any kind.
- Programmable digital filter.
- Requires +5VDC supply.
- Transient suppression on RS-485 communications lines.
- Screw terminal plug connectors supplied.

### APPLICATIONS

- Process monitoring and control
- Remote data logging to any host computer
- Product testing
- Interface to PLC

### GENERAL DESCRIPTION

The DIN-100 Sensor to Computer Modules are a family of data acquisition modules that convert analog input signals to digital data and transmit via RS-485 to a controller which may be a computer or other processor-based equipment. The modules can measure temperature, pressure, voltage, current, digital input or digital output signals. The modules provide direct connection to a wide variety of sensors and perform all signal conditioning, scaling, linearization and conversion to either linearized ASCII data values or Modbus RTU data values.

Features such as address, baud rate, parity, echo, etc., are selectable using simple commands over the RS-485 port. The selections are stored in nonvolatile EEPROM which maintains data even after power is removed.

## DIN-100 SPECIFICATIONS (typical at +25°C and nominal power supply unless otherwise noted)

### Analog

- Single channel analog input.
- Maximum CMV, input to output at 60Hz: 500V rms.
- Leakage current, input to output at 115Vrms, 60Hz: <math><2\mu\text{A}</math> rms.
- 15 bit measurement resolution.
- 8 conversions per second.
- Autozero & autocalibration—no adjustment pots.

### Digital

- 8-bit CMOS microcomputer.
- Digital scaling, linearization and calibration .
- Nonvolatile memory eliminates pots and switches.

### Digital filtering

- Small and large signal with user selectable time constants from 0 to 16 seconds.

### Communications

- Communications in MODBUS-RTU via RS-485 ports.
- Selectable baud rates: 300, 600, 1200, 2400, 4800, 9600, 19200, 38400.
- NRZ asynchronous data format; 1 start bit, 8 data bits, 1 parity bit and 1 stop bit.
- Parity: odd, even, none.
- User selectable channel address.
- Up to 247 multidrop modules per host serial port.
- Communications distance up to 4,000 feet (RS-485).
- Transient suppression on RS-485 communications lines.
- All communications setups stored in EEPROM.

### Power

Requirements: Regulated +5Vdc ,  
0.75W max (DIN-150, 2.0W max.).  
Protected against power supply reversals.

### Environmental

Temperature Range: Operating -25°C to +70°C.  
Storage -25°C to +85°C.  
Relative Humidity: 0 to 95% noncondensing.

### Warranty

12 months on workmanship and material.

### Mechanicals and Dimensions

ABS case with screw terminal barrier plug (supplied).

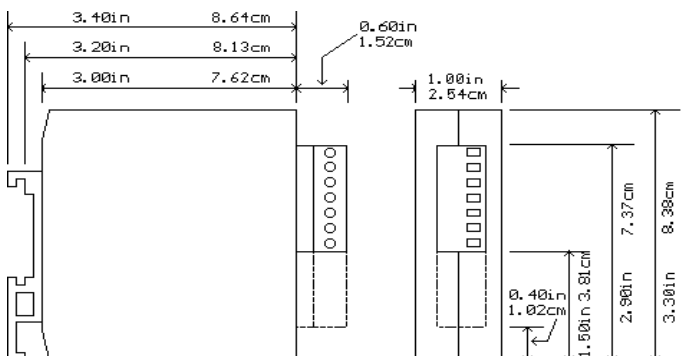

### DIN-100 Voltage Inputs

- Voltages:  $\pm 10\text{mV}$ ,  $\pm 100\text{mV}$ ,  $\pm 1\text{V}$ ,  $\pm 5\text{V}$ ,  $\pm 10\text{V}$ ,  $\pm 100\text{Vdc}$ .
- Resolution: 0.01% of FS (4 digits).
- Accuracy:  $\pm 0.02\%$  of FS max.
- Common mode rejection: 100dB at 50/60Hz.
- Zero drift:  $\pm 1$  count max (autozero).
- Span tempco:  $\pm 50\text{ppm}/^\circ\text{C}$  max.
- Input burnout protection to 250Vac .
- Input impedance:  $\leq \pm 1\text{V}$  input =  $100\text{M}\Omega$  min.  
 $\geq \pm 5\text{V}$  input =  $1\text{M}\Omega$  min.

### DIN-120 Current Inputs

- Currents: 4-20mAdc.
- Resolution: 0.04% of FS.
- Accuracy: 0.04% of FS.
- Common mode rejection: 100dB at 50/60Hz.
- Zero drift:  $\pm 1$  count max (autozero).
- Span tempco:  $\pm 50\text{ppm}/^\circ\text{C}$  max.
- Voltage drop:  $\pm 0.1\text{V}$  max.

### DIN-130 Thermocouple Inputs

- Thermocouple types: J, K, T, E, R, S, B, C (factory set).
- Ranges: J = -200°C to +760°C    B = 0°C to +1820°C  
K = -150°C to +1250°C    S = 0°C to +1750°C  
T = -200°C to +400°C    R = 0°C to +1750°C  
E = -100°C to +1000°C    C = 0°C to +2315°C
- Resolution:  $\pm 1^\circ$ .
- Overall Accuracy (error from all sources) from 0 to +40°C ambient:  $\pm 1.0^\circ\text{C}$  max (J, K, T, E).  
 $\pm 2.5^\circ\text{C}$  max (R, S, B, C)(300°C TO FS).
- Common mode rejection: 100dB at 50/60Hz.
- Input impedance:  $100\text{M}\Omega$  min.
- Lead resistance effect:  $<20\mu\text{V}$  per  $350\Omega$ .
- Open thermocouple indication.
- Input burnout protection to 250Vac.
- Overrange indication.
- Automatic cold junction compensation and linearization.

### DIN-140 RTD Inputs

- RTD types:  $\alpha = .00385$ ,  $.00392$ ,  $100\Omega$  at  $0^\circ\text{C}$ ,  
 $.00388$ ,  $100\Omega$  at  $25^\circ\text{C}$ .
- Ranges:  $.00385 = -200^\circ\text{C}$  to  $+850^\circ\text{C}$ .  
 $.00392 = -200^\circ\text{C}$  to  $+600^\circ\text{C}$ .  
 $.00388 = -100^\circ\text{C}$  to  $+125^\circ\text{C}$ .
- Resolution:  $0.1^\circ$ .
- Accuracy:  $\pm 0.3^\circ\text{C}$ .
- Common mode rejection: 100dB at 50/60Hz.
- Input connections: 2, 3, or 4 wire.
- Excitation current: 0.25mA.
- Lead resistance effect: 3 wire -  $2.5^\circ\text{C}$  per  $\Omega$  of imbalance.  
4 wire - negligible.
- Max lead resistance:  $50\Omega$ .
- Input burnout protection to 120Vac .
- Automatic linearization and lead compensation.

Specifications are subject to change without notice.

---

### DIN-145 Thermistor Inputs

- Thermistor types: 2252Ω at 25°C, TD Series
  - Ranges: 2252Ω = -0°C to +100°C.  
TD = -40°C to +150°C.
  - Resolution: 2252Ω = 0.01°C or F.  
TD = 0.1°C or F
  - Accuracy: 2252Ω = ±0.1°C.  
TD = ±0.2°C
  - Common mode rejection: 100dB at 50/60Hz.
  - Input burnout protection to 30Vdc .
- 

### DIN-150 Bridge Inputs

- Voltage Ranges: ±30mV, ±100mV.
  - Resolution: 10μV (mV spans).  
0.02% of FS (V span).
  - Accuracy: ±0.05% of FS max.
  - Common mode rejection: 100dB at 50/60Hz.
  - Input burnout protection to 30Vdc .
  - Offset Control: Full input range.
  - Excitation Voltage: 5V, 10Vdc, 50mA max.
  - Zero drift: ±1μV/°C max.
  - Span tempco: ±50ppm/°C max.
- 

### DIN-160 Frequency Inputs

- Range: 1Hz to 20KHz.
  - Resolution: 0.005% of reading + 0.01Hz.
  - Accuracy: ±0.01% of reading ±0.01Hz.
  - Tempco: ±20ppm/°C.
  - Input impedance: 1MΩ.
  - Switching level: selectable 0V, +2.5V.
  - Hysteresis: Adjustable 10mV-1.0V.
  - Input burnout protection: 250Vac .
- 

### DIN-170 Digital Inputs/Outputs

- 6 digital inputs or 6 digital outputs.
  - Input voltage levels: ±30V without damage.
  - Input switching levels: High, 3.5V min., Low, 1.0V max.
  - Outputs: open collector to 30V, 100mA max. load.
  - Vsat: 1.0V max @ 100mA.
  - Inputs/Outputs are read/set in parallel.
  - Isolated from power supply ground.
- 

### DIN-190 RS-232/485 Converter/Repeater

- Baud Rates: 300-115200 (Dip-switch selectable).
  - Termination and biasing resistors included (selectable via internal jumpers).
  - Isolated to 500Vrms.
- 

**General Description continued:** The key to the DGH product concept is that the modules are easy to use. You do not need engineering experience in complicated data acquisition hardware. With the DGH modules, anyone familiar with a personal computer can construct a data acquisition system. This modular approach to data acquisition is extremely flexible, easy to use and cost effective. Data is acquired on a per channel basis so you only buy as many channels as you need. The modules can be mixed and matched to fit your application. They can be placed remote from the host and from each other. You can string up to 247 modules on a twisted pair of wires by using RS-485 with repeaters.

All modules are supplied with screw terminal plug connectors. The connectors allow system expansion, reconfiguration or repair without disturbing field wiring.

Utility software is available from DGH to make the DIN-100 easier to learn and use. The software is provided at no charge on request with a purchase order and is not copy protected.

### THEORY OF OPERATION

Each DGH module is a complete single-channel data acquisition system. Each unit contains analog signal conditioning circuits optimized for a specific input type. Sensor signals are converted to digital data with a microprocessor-controlled integrating A/D converter. Offset and gain errors in the analog circuitry are continuously monitored and corrected using microprocessor techniques. The DIN-100 converts the digital signal data and stores the resultant data in a memory buffer. The modules continuously convert data at the rate of 8 conversions per second and store the latest result in the buffer.

Host processors may request data by sending a query to the module. The DIN-100 will instantly respond by communicating the memory buffer data back to the host processor. Up to 247 modules may be linked to a single RS-485 port. Each module on a serial line is identified by a unique user-programmable address. This addressing technique allows modules to be interrogated in any order.

### DIGITAL INPUTS/OUTPUTS

DIN-170 digital output modules contain open-collector transistor switches that may be controlled by the host processors. These switches may be used to control solid-state relays which in turn may control heaters, pumps and other power equipment. The digital inputs may be read by the host processor and used to sense the state of remote digital signals. They are ideal for sensing the state of limit or safety switches.

---

## DIGITAL FILTER

The DIN-100 analog input modules include two unique programmable single pole digital filters. The filter is used to smooth analog data in noisy environments. Separate time constants may be specified for small and large signal changes. Typically a large time constant is specified for small signal changes to filter out noise and provide stable output readings. A smaller time constant may be chosen for large signal changes to provide fast response to such changes.

## COMMAND SET

The DIN-100 series uses the Modbus RTU or the DGH ASCII protocol for communication.

The Modbus RTU binary protocol uses a master-slave technique, in which only the master device can initiate transactions. The slave devices respond by supplying the requested data to the master or by taking the action requested in the query. The master can address any slave device. The returned messages are considered response messages. The supported master codes are:

### Modbus RTU Functions and Descriptions

- 01 Read Coil Status (Digital Inputs)
- 04 Read Input Register (Analog Inputs)
- 05 Force Single Coil (One Digital Input)
- 06 Preset Single Register (DGH/RTU Protocol)
- 15 Force Multiple Coils (Multiple Digital Output)

The DGH ASCII protocol is a command and response protocol using ASCII characters for easy troubleshooting and interpretation of data values.

## DIN-100 Series ASCII Command Set.

Command and Definition	Typical Command Message (\$ prompt)	Typical Response Message
DI Digital Input	\$1DI	*0003
DO Digital Output	\$1DOFF	*
RD Read Data	\$1RD	*+00072.00
RS Read Setup	\$1RS	*31070142
RSU Read Setup	\$1RSU	*31070142
RZ Read Zero	\$1RZ	*+00000.00
WE Write Enable	\$1WE	*

### Write Protected Commands.

CZ Clear Zero	\$1CZ	*
RR Remote Reset	\$1RR	*
SU Setup Module	\$1SU31070142	*
TS Trim Span	\$1TS+00600.00	*
TZ Trim Zero	\$1TZ+00000.00	*

## SETUP

The DIN-100 series are initiated at the factory using the DGH ASCII protocol. This allows setup and configuration, including the Modbus device address, to be easily performed using the DGH setup software or a dumb terminal. Each DIN-

100 module must be properly configured before installation into a Modbus system.

## UTILITY SOFTWARE

Complimentary Utility Software is included with each purchase order. The software is compatible with Windows 95, 98, NT 4.0+, 2000 operating systems and distributed on CD-ROM. The Utility Software simplifies configuration of all user-selectable options such as device address, baud rate and filtering constants. The latest version of our software is always downloadable from our web site at [www.dghcorp.com](http://www.dghcorp.com).

## PROCESS CONTROL SOFTWARE

Modbus RTU protocol is supported by virtually all commercial process control software programs available today. These programs operate on IBM and compatible personal computers in the Windows 95, 98, NT and IBM OS/2 environments.

## DIN-100 SERIES ORDERING GUIDE

### Voltage Input

- DIN-110 10mV Input/RS-485 Output
- DIN-111 100mV Input/RS-485 Output
- DIN-112 1V Input/RS-485 Output
- DIN-113 5V Input/RS-485 Output
- DIN-114 10V Input/RS-485 Output
- DIN-115 100V Input/RS-485 Output

### Current Inputs

- DIN-125 4-20mA Input/RS-485 Output

### Thermocouple Inputs

- DIN-131 J Thermocouple Input/RS-485 Output
- DIN-132 K Thermocouple Input/RS-485 Output
- DIN-133 T Thermocouple Input/RS-485 Output
- DIN-134 E Thermocouple Input/RS-485 Output
- DIN-135 R Thermocouple Input/RS-485 Output
- DIN-136 S Thermocouple Input/RS-485 Output
- DIN-137 B Thermocouple Input/RS-485 Output
- DIN-138 C Thermocouple Input/RS-485 Output

### RTD/Thermistor Inputs

- DIN-141 .00385 RTD Input/RS-485 Output
- DIN-142 .00392 RTD Input/RS-485 Output
- DIN-143 .00388 RTD Input/RS-485 Output
- DIN-145 2252Ω Thermistor Input/RS-485 Output
- DIN-146 TD Thermistor Input/RS-485 Output

### Bridge Inputs

- DIN-151 30mV Bridge Input, 5V Excitation/RS-485 Output
- DIN-152 30mV Bridge Input, 10V Excitation/RS-485 Output
- DIN-153 100mV Bridge Input, 5V Excitation/RS-485 Output
- DIN-154 100mV Bridge Input, 10V Excitation/RS-485 Output

### Timer and Frequency Inputs

- DIN-161 Frequency Input/RS-485 Output

### Digital Inputs/Outputs

- DIN-171 6 Digital Inputs/RS-485 Output
- DIN-172 6 Digital Outputs/RS-485 Output

### RS-232/485 Converter/Repeater

- DIN-191 RS-232/485 Converter
- DIN-192 RS-485 Repeater