

Actual size of sensor

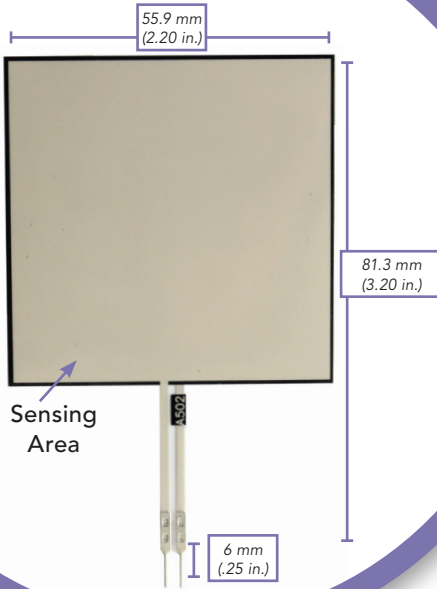

FlexiForce™

Standard Model A502

The FlexiForce™ A502 is a square sensor, with a sensing area measuring 50.8 mm x 50.8 mm (2 in. x 2 in.). This sensor is available off-the-shelf for easy proof of concept. The A502 can be used with our test & measurement, prototyping, and embedding electronics, including the OEM Development Kit, FlexiForce Quickstart Board, and the ELF™ System*. You can also use your own electronics, or multimeter.



Physical Properties

Thickness	0.203 mm (0.008 in.)
Length	81.3 mm (3.20 in.)**
Width	55.9 mm (2.20 in.)
Sensing Area	50.8 mm x 50.8 mm (2 in. x 2 in.)
Connector	2-pin Male Square Pin
Substrate	Polyester
Pin Spacing	2.54 mm (0.1 in.)

Benefits

- Thin and flexible
- Low-power
- Ideal for prototyping and integration
- Easy to use

✓ ROHS COMPLIANT

* Sensor will require an adapter/extender to connect to the ELF System. Contact your Tekscan representative for assistance.

** Length does not include pins. Please add approximately 6 mm (0.25 in.) for pin length for a total length of approximately 87 mm (3.4 in.).

Typical Performance

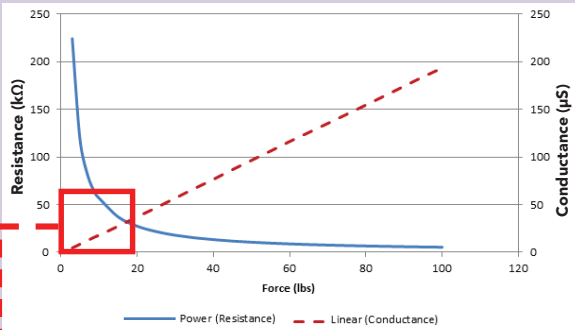

Superior performance and range compared to other sensors of its kind

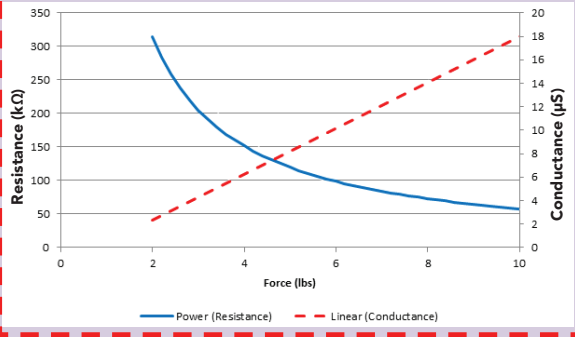

Voltage (V)	Force (lbs)	Resistance (kΩ)	Conductance (μS)
0.5	20	34.36	29.11
0.5	40	17.14	58.33
0.5	60	11.57	86.41
0.5	80	8.71	114.76
0.5	100	6.97	143.54

- Sensor acceptance criteria $\pm 40\%$ of nominal
- Sensor resistance measured 20 seconds after applied load
- Sensor loaded through a polycarbonate puck equal to 68% (2.72 in²) of total active area
- Sensor was not attached to any drive circuitry

Standard Force Ranges as Tested with Circuit Shown

222 N (0 - 50 lb) †

† This sensor can measure up to 44,448 N (10,000 lb). In order to measure higher forces, apply a lower drive voltage (-0.5 V, -0.25 V, etc.) and reduce the resistance of the feedback resistor (1kΩ min.) To measure lower forces, apply a higher drive voltage and increase the resistance of the feedback resistor.

Sensor output is a function of many variables, including interface materials. Therefore, Tekscan recommends the user calibrate each sensor for the application.

Recommended Circuit

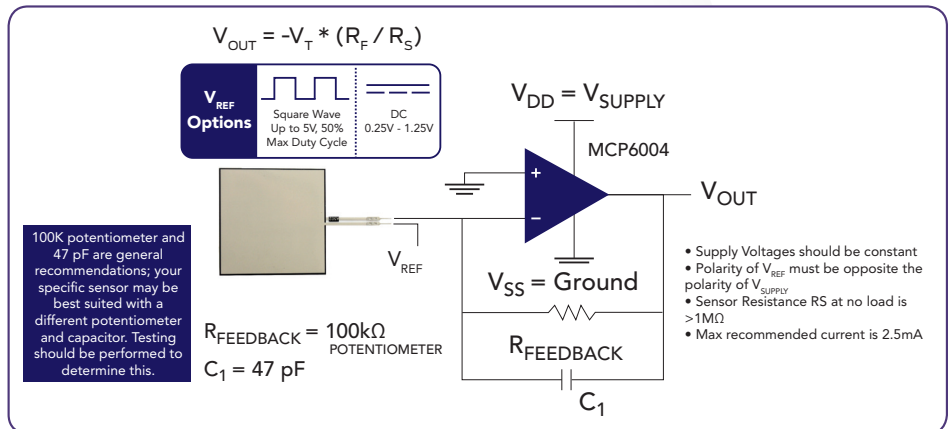

	Typical Performance	Evaluation Conditions
Linearity (Error)	< $\pm 3\%$ of full scale	Line drawn from 0 to 50% load
Repeatability	< $\pm 2.5\%$	Conditioned sensor, 80% of full force applied
Hysteresis	< 4.5% of full scale	Conditioned sensor, 80% of full force applied
Drift	< 5% per logarithmic time scale	Constant load of 111 N (25 lb)
Response Time	< 5μsec	Impact load, output recorded on oscilloscope
Operating Temperature	-40°C - 60°C (-40°F - 140°F)	Convection and conduction heat sources

All data above was collected utilizing an Op Amp Circuit. If your application cannot allow an Op Amp Circuit, visit www.tekscan.com/flexiforce-integration-guides, or contact a FlexiForce Applications Engineer.

Force reading change per degree of temperature change = 0.36%/°C ($\pm 0.2\%/^{\circ}F$).



PURCHASE TODAY ONLINE AT WWW.TEKSCAN.COM/STORE

