

FlexiForce™

Standard Model A101

Actual size of sensor

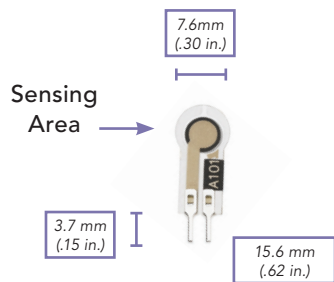

The FlexiForce A101 is our smallest standard piezoresistive force sensor. The A101 design is optimized for high volume manufacturing and is ideal for embedding into products and applications. This sensor is available off-the-shelf for easy proof of concept. The A101 can be used with our test & measurement, prototyping, and embedding electronics, including the OEM Development Kit, FlexiForce Quickstart Board, and the ELF™ System*. You can also use your own electronics, or multimeter.



Physical Properties

Thickness	0.203 mm (0.008 in.)
Length	15.6 mm (.62 in.)**
Width	7.6 mm (0.30 in.)
Sensing Area	3.8 mm (0.15 in.) diameter
Connector	2-pin Male Square Pin
Substrate	Polyester
Pin Spacing	2.54 mm (0.1 in.)

Benefits

- Small size is ideal for prototyping and integration
- Thin and flexible
- Easy to use

✓ ROHS COMPLIANT

* Sensor will require an adapter/extender to connect to the ELF System. Contact your Tekscan representative for assistance.

**Length does not include pins. Please add approximately 3.7 mm (0.15 in.) for pin length for a total length of approximately 19.3 mm (0.75 in.).

Typical Performance

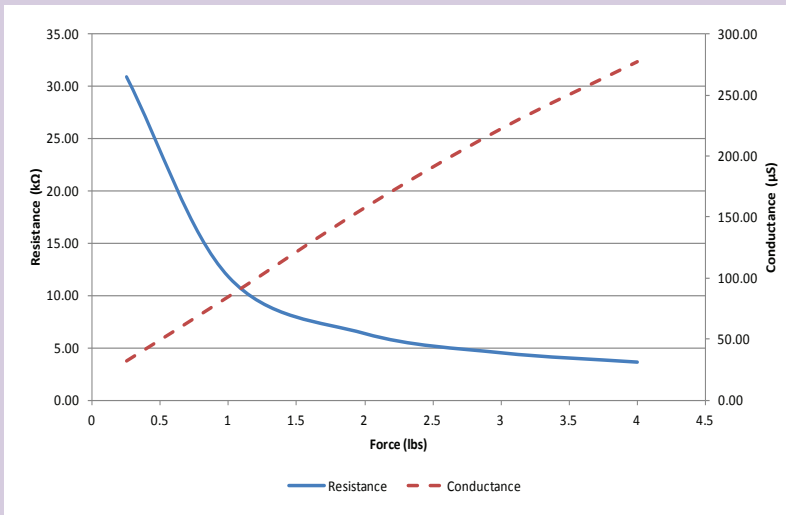

Voltage (V)	Force (lbs)	Resistance (kΩ)	Conductance (μS)
0.5	0.25	30.85	32.41
0.5	1	11.73	85.20
0.5	2	6.33	158.00
0.5	3	4.49	222.59
0.5	4	3.60	277.53

- Sensor acceptance criteria ±40% of nominal
- Sensor resistance measured 20 seconds after applied load
- Sensor loaded through a polycarbonate puck equal to 68% (0.0123 in²) of total active area
- Sensor was not attached to any drive circuitry

Standard Force Ranges as Tested with Circuit Shown

18 N (0 - 4 lb) †

† This sensor can measure up to 44 N (10 lb). In order to measure higher forces, apply a lower drive voltage (-0.5 V, -0.25 V, etc.) and reduce the resistance of the feedback resistor (1kΩ min.). To measure lower forces, apply a higher drive voltage and increase the resistance of the feedback resistor.

Sensor output is a function of many variables, including interface materials. Therefore, Tekscan recommends the user calibrate each sensor for the application.

Recommended Circuit

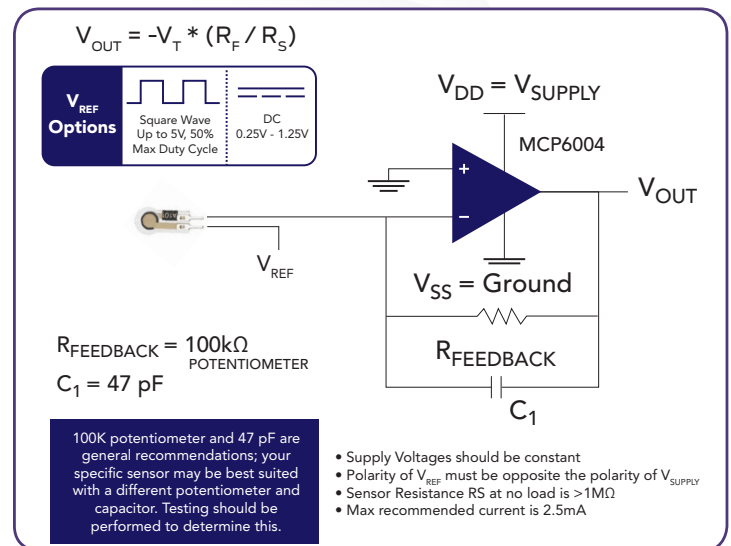

	Typical Performance	Evaluation Conditions
Linearity (Error)	< ±3% of full scale	Line drawn from 0 to 50% load
Repeatability	< ±2.5%	Conditioned sensor, 80% of full force applied
Hysteresis	< 4.5% of full scale	Conditioned sensor, 80% of full force applied
Drift	< 5% per logarithmic time scale	Constant load of 111 N (25 lb)
Response Time	< 5μsec	Impact load, output recorded on oscilloscope
Operating Temperature	-40°C - 60°C (-40°F - 140°F)	Convection and conduction heat sources

*All data above was collected utilizing an Op Amp Circuit. If your application cannot allow an Op Amp Circuit, visit www.tekscan.com/flexiforce-integration-guides, or contact a FlexiForce Applications Engineer.

Force reading change per degree of temperature change = 0.36%/°C (±0.2%/°F).



PURCHASE TODAY ONLINE AT WWW.TEKSCAN.COM/STORE

