

This manual contains instructions for communication functions of the ACS-13A.

Serial communication and Console communication cannot be used together.
 When performing Serial communication, remove the exclusive cable (CMA) from the USB port of the PC and loader connector of the ACS-13A.
 When performing Console communication, it is not required to remove the Serial communication cables.
 However, do not send a command from the master side.

1. System configuration

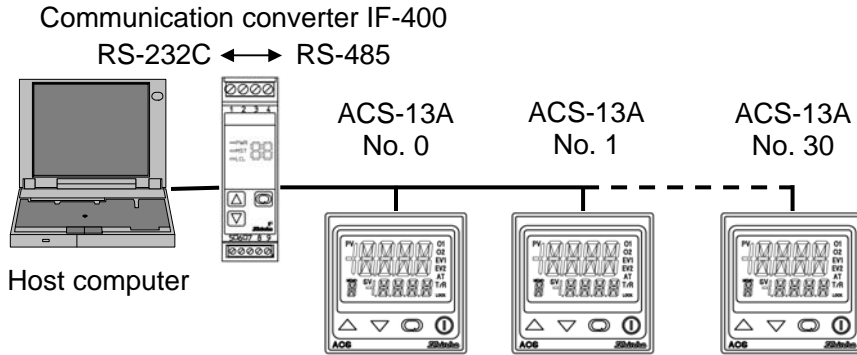

(Fig. 1-1)

2. Wiring

When using communication converter IF-400

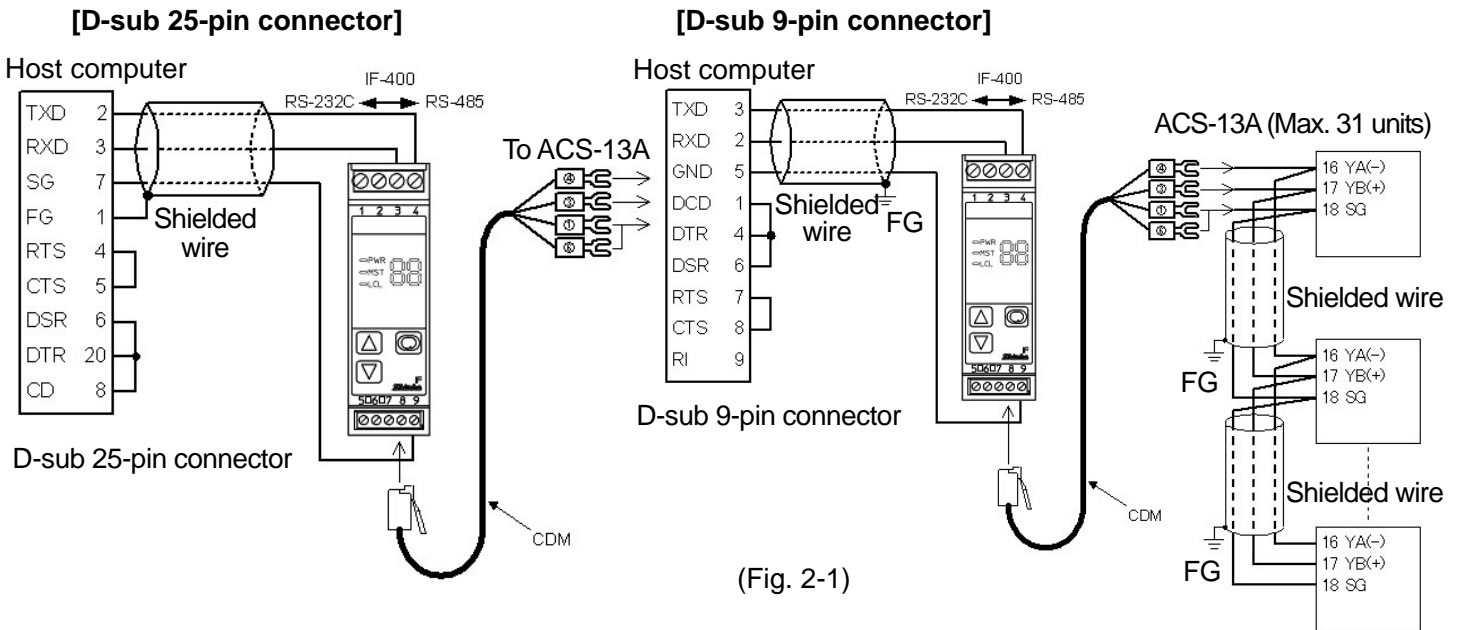

Shielded wire

Connect only one side of the shielded wire to the FG terminal so that current cannot flow to the shielded wire. If both sides of the shielded wire are connected to the FG terminal, the circuit will be closed between the shielded wire and the ground. As a result, current will run through the shielded wire and this may cause noise. Be sure to ground FG terminal.

Recommended cable: OTSC-VB 2PX0.5SQ (made by Onamba Co., Ltd.) or equivalent (Use a twisted pair cable.)

Terminator (Terminal resistor)

Communication converter IF-400 (sold separately) has a built-in terminator.

The terminator is mounted at the end of the wire when connecting a personal computer with multiple peripheral devices. The terminator prevents signal reflection and disturbance.

Do not connect terminator with the communication line because each ACS-13A has built-in pull-up and pull-down resistors instead of a terminator.

3. Communication parameter setting

Set each communication parameter following the procedures below.

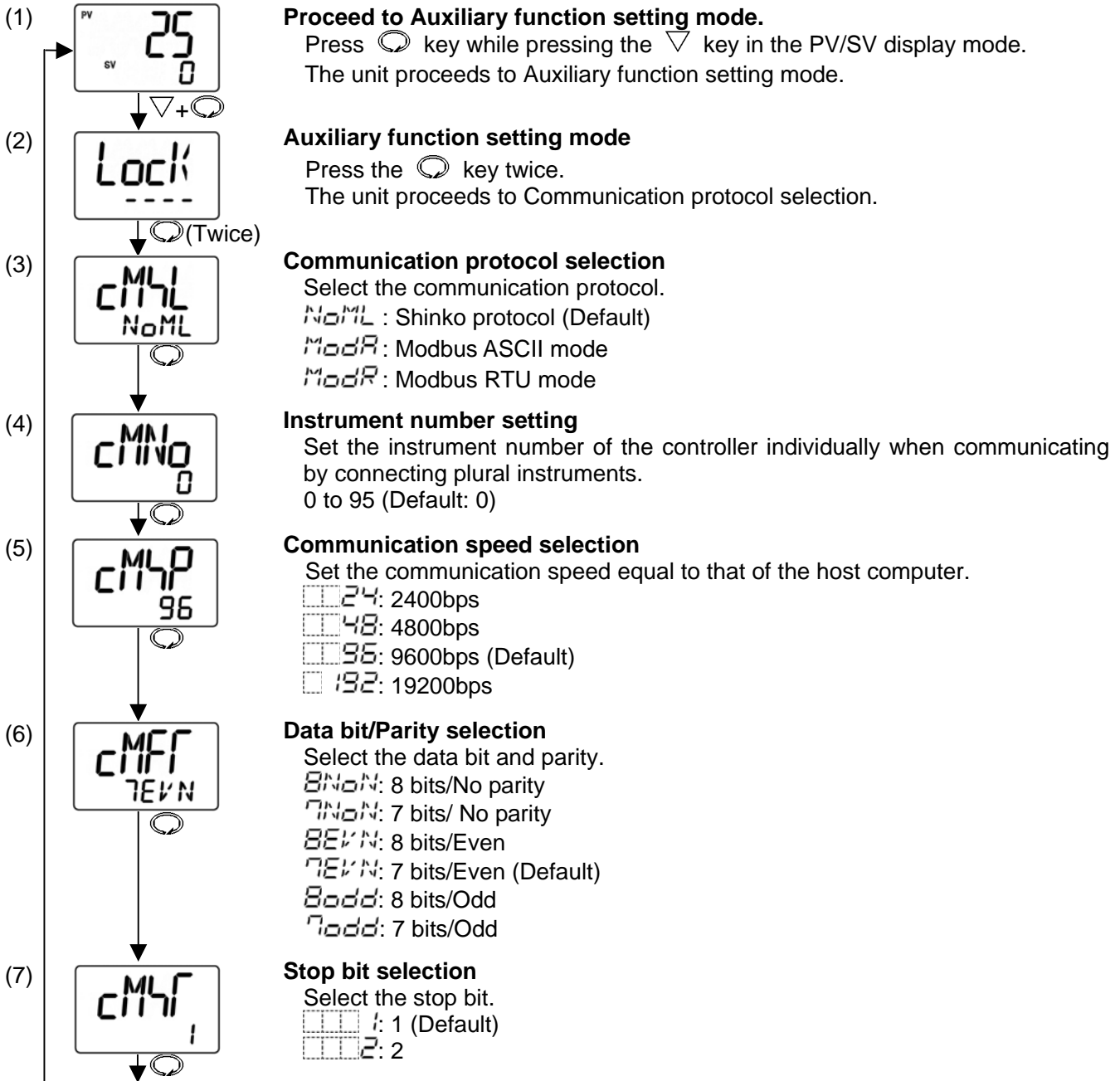

4. Communication procedure

Communication starts with command transmission from the host computer (hereafter Master) and ends with the response of the ACS-13A (hereafter Slave).

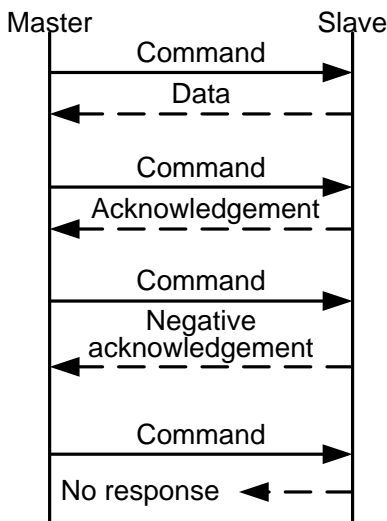

(Fig.4-1)

- **Response with data**
When the master sends the reading command, the slave responds with the corresponding set value or current status.
- **Acknowledgement**
When the master sends the setting command, the slave responds by sending the acknowledgement after the processing is terminated.
- **Negative acknowledgement**
When the master sends a non-existent command or value out of the setting range, the slave returns a negative acknowledgement.
- **No response**
The slave will not respond to the master in the following cases:
 - Global address (Shinko protocol) is set.
 - Broadcast address (Modbus protocol) is set.
 - Communication error (framing error, parity error)
 - Checksum error(Shinko protocol), LRC discrepancy(Modbus ASCII mode), CRC-16 discrepancy(Modbus RTU mode)

Communication timing of the RS-485

Master side (Notice on programming)

Set the program so that the master can disconnect the transmitter from the communication line within a 1 character transmission period after sending the command in preparation for reception of the response from the slave.

To avoid the collision of transmissions between the master and the slave, send the next command after carefully checking that the master received the response.

Slave side

When the slave starts transmission through a communication line, the slave is arranged so as to provide an idle status (mark status) transmission period of 1 or more characters before sending the response to ensure synchronization on the receiving side.

The slave is arranged so as to disconnect the transmitter from the communication line within a 1 character transmission period after sending the response.

5. Shinko protocol

5.1 Transmission mode

Shinko protocol is composed of ASCII codes.

Hexadecimal (0 to 9, A to F), which is divided into high order (4-bit) and low order (4-bit) out of 8-bit binary data in command is transmitted as ASCII characters.

Data format Start bit : 1 bit
 Data bit : 7 bits
 Parity : Even
 Stop bit : 1 bit

Error detection: Checksum

5.2 Command configuration

All commands are composed of ASCII.

The data (set value, decimal number) is represented with hexadecimal number.

The negative numbers are represented with 2's complement.

Numerals written below the command represent number of characters.

(1) Setting command

Header (02H)	Address	Sub address (20H)	Command type (50H)	Data item	Data	Checksum	Delimiter (03H)
1	1	1	1	4	4	2	1

(2) Reading command

Header (02H)	Address	Sub address (20H)	Command type (20H)	Data item	Checksum	Delimiter (03H)
1	1	1	1	4	2	1

(3) Response with data

Header (06H)	Address	Sub address (20H)	Command type (20H)	Data item	Data	Checksum	Delimiter (03H)
1	1	1	1	4	4	2	1

(4) Acknowledgement

Header (06H)	Address	Checksum	Delimiter (03H)
1	1	2	1

(5) Negative acknowledgement

Header (15H)	Address	Error code	Checksum	Delimiter (03H)
1	1	1	2	1

Header : Control code to represent the beginning of the command or the response.

ASCII codes are used.

Setting command, Reading command : STX (02H) fixed

Response with data, Acknowledgement: ACK (06H) fixed

Negative acknowledgement : NAK (15H) fixed

Instrument number (Address): Numbers by which the master discerns each slave.

Instrument number 0 to 94 and Global address 95.

ASCII codes (20H to 7FH) are used by adding 20H to instrument numbers 0 to 95 (00H to 5FH).

95 (7FH) is called Global address, which is used when the same command is sent to all the slaves connected. However, the response is not returned.

Sub address : 20H fixed

Command type: Code to discern Setting command (50H) and Reading command (20H)

Data item : Data classification of the command object.

Composed of hexadecimal 4 digits (Refer to "7. Communication command table".)

Data : The contents of data (set value) differs depending on the setting command.

Composed of hexadecimal 4 digits (Refer to "7. Communication command table".)

Checksum : 2-character data to detect communication errors. (Refer to "5.3 Checksum calculation".)

Delimiter : Control code to represent the end of command

03H fixed

Error code : Represents an error type. Composed of hexadecimal 1 digit.

1 (31H)-----Non-existent command

2 (32H)-----Not used

3 (33H)-----Setting outside the setting range

4 (34H)-----Unsettable status (e.g. AT is performing)

5 (35H)-----During setting mode by keypad operation

5.3 Checksum calculation

Checksum is used to detect receiving errors in the command or data.

Set the program for the master side as well to calculate the checksum of the response data from the slaves so that the communication errors can be checked.

The ASCII code (hexadecimal) corresponding to the characters which range from the address to that before the checksum is converted to binary notation, and the total value is calculated.

The lower 2-digit of the total value are converted to 2's complements, and then to hexadecimal figures, that is, ASCII code for the checksum.

Checksum calculation example

SV: 600°C (0258H)

Address (instrument number): 0 (20H)

- 1's complement: Reverse each binary bit. 0 will become 1 and vice versa.
- 2's complement: Add 1 to 1's complements.

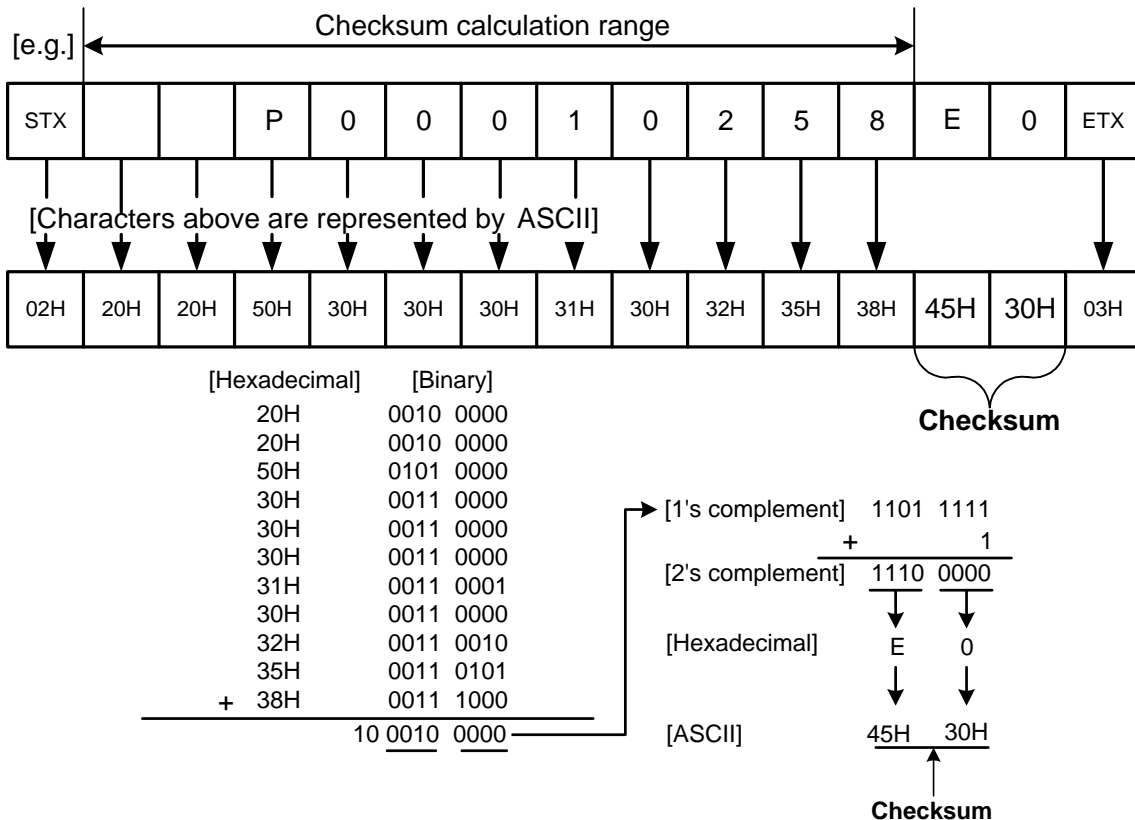

5.4 Command example

(1) Reading (Address 1, PV)

- Reading command from the master

Header	Address	Sub address	Command type	Data item	Checksum	Delimiter
(02H)	(21H)	(20H)	(20H)	[0080H] (30H 30H 38H 30H)	(44H 37H)	(03H)

- A response from the slave in normal status [When PV=25°C (0019H)]

Header	Address	Sub address	Command type	Data item	Data	Checksum	Delimiter
(06H)	(21H)	(20H)	(20H)	[0080H] (30H 30H 38H 30H)	[0019H] (30H 30H 31H 39H)	(30H 44H)	(03H)

(2) Reading (Address 1, SV)

- Reading command from the master

Header	Address	Sub address	Command type	Data item	Checksum	Delimiter
(02H)	(21H)	(20H)	(20H)	[0001H] (30H 30H 30H 31H)	(44H 45H)	(03H)

- A response from the slave in normal status [When SV=600°C (0258H)]

Header	Address	Sub address	Command type	Data item	Data	Checksum	Delimiter
(06H)	(21H)	(20H)	(20H)	[0001H] (30H 30H 38H 30H)	[0258H] (30H 32H 35H 38H)	(30H 46H)	(03H)

(3) Setting (Address 1, SV) [when setting SV to 600°C (0258H)]

- Setting command from the master

Header	Address	Sub address	Command type	Data item	Data	Checksum	Delimiter
(02H)	(21H)	(20H)	(50H)	[0001H] (30H 30H 30H 31H)	[0258H] (30H 32H 35H 38H)	(44H 46H)	(03H)

- A response from the slave in normal status

Header	Address	Checksum	Delimiter
(06H)	(21H)	(44H 46H)	(03H)

6. Modbus protocol

6.1 Transmission mode

There are 2 transmission modes (ASCII and RTU) in Modbus protocol.

6.2 ASCII mode

Hexadecimal (0 to 9, A to F), which is divided into high order (4-bit) and low order (4-bit) out of 8-bit binary data in command is transmitted as ASCII characters.

Data format Start bit : 1 bit
 Data bit : 7 bits (8 bits) Selectable
 Parity : Even (Odd, No parity) Selectable
 Stop bit : 1 bit (2 bits) Selectable

Error detection : LRC (Longitudinal Redundancy Check)

Data interval : 1 second or less (Max.1sec of interval between characters)

(1) Message configuration

ASCII mode message is configured to start by Header [: (colon)(3AH)] and end by Delimiter [CR (carriage return) (0DH) + LF (Line feed)(0AH)].

Header	Slave address	Function Code	Data	Error check LRC	Delimiter (CR)	Delimiter (LF)
(:)						

Slave address

Slave address is an individual instrument number on the slave side and is set within the range 0 to 95 (00H to 5FH).

The master identifies slaves by the slave address of the requested message.

The slave informs the master which slave is responding to the master by placing its own address in the response message.

Slave address 0 (00H, broadcast address) can identify all the slaves connected. However slaves do not respond.

Function code

The function code is the command code for the slave to undertake the following action types.

Function code	Contents
03 (03H)	Reading the set value and information from slaves
06 (06H)	Setting to slaves

Function code is used to discern whether the response is normal (acknowledgement) or if any error (negative acknowledgement) is occurred when the slave returns the response message to the master.

When acknowledgement is returned, the slave simply returns the original function code.

When negative acknowledgement is returned, the MSB of the original function code is set as 1 for the response.

For example, when the master sends request message setting 10H to the function code by mistake, slave returns 90H by setting the MSB to 1, because the former is an illegal function.

For negative acknowledgement, the exception codes below are set to the data of the response message and returned to the master in order to inform it of what kind of error has occurred.

Exception code	Contents
1 (01H)	Illegal function (Non-existent function)
2 (02H)	Illegal data address (Non-existent data address)
3 (03H)	Illegal data value (Value out of the setting range)
17 (11H)	Shinko error code 4 (Unsettable status, e.g. AT is performing)
18 (12H)	Shinko error code 5 (During setting mode by keypad operation)

Data

Data differs depending on the function code.

A request message from the master is composed of data item, number of data and setting data.

A response message from the slave is composed of a number of bytes, data and exception codes in negative acknowledgements. The number of data to be dealt with in one message is "1".

Therefore the number of data is fixed as (30H)(30H)(30H)(31H).

Effective range of data is -32768 to 32767 (8000H to 7FFFH).

Error check: 2-character data to detect communication errors.

Refer to "(2) Error check of ASCII mode".

(2) Error check of ASCII mode

After calculating LRC (Longitudinal Redundancy Check) from the slave address to the end of data, the calculated 8-bit data is converted to two ASCII characters and are appended to the end of message.

How to calculate LRC

- ① Create a message in RTU mode.
- ② Add all the values from the slave address to the end of data. This is assumed as X.
- ③ Make a complement for X (bit reverse). This is assumed as X.
- ④ Add a value of 1 to X. This is assumed as X.
- ⑤ Set X as an LRC to the end of the message.
- ⑥ Convert the whole message to ASCII characters.

(3) Message example of ASCII mode

① Reading (Address 1, PV)

- A request message from the master

The number of data means the data item to be read, and it is fixed as 1 (30H 30H 30H 31H).

Header	Slave address	Function code	Data item	Number of data	Error check	Delimiter
(3AH)	(30H 31H)	(30H 33H)	[0080H] (30H 30H 38H 30H)	[0001H] (30H 30H 30H 31H)	LRC (37H 42H)	CR+LF (0DH 0AH)

- Response message from the slave in normal status [When PV=600°C (0258H)]

The number of response byte means the number of byte of the data which has been read, and it is fixed as 2 (30H 32H).

Header	Slave address	Function code	Number of response byte	Data	Error check	Delimiter
(3AH)	(30H 31H)	(30H 33H)	[02H] (30H 32H)	[0258H] (30H 32H 35H 38H)	LRC (41H 30H)	CR+LF (0DH 0AH)

② Reading (Address 1, SV)

- A request message from the master

The number of data means the data item to be read, and it is fixed as 1 (30H 30H 30H 31H).

Header	Slave address	Function code	Data item	Number of data	Error check	Delimiter
(3AH)	(30H 31H)	(30H 33H)	[0001H] (30H 30H 30H 31H)	[0001H] (30H 30H 30H 31H)	LRC (46H 41H)	CR+LF (0DH 0AH)

- Response message from the slave in normal status [When SV=600°C (0258H)]
The number of response byte means the number of byte of the data which has been read, and it is fixed as 2 (30H 32H).

Header (3AH)	Slave address (30H 31H)	Function code (30H 33H)	Number of response byte [02H] (30H 32H)	Data [0258H] (30H 32H 35H 38H)	Error check LRC (41H 30H)	Delimiter CR+LF (0DH 0AH)
-----------------	----------------------------	----------------------------	---	--------------------------------------	------------------------------	---------------------------------

- Response message from the slave in exception (error) status (When a data item has been mistaken)
The function code MSB is set to 1 for the response message in exception (error) status [83H (38H 33H)].
The exception code 02H (30H 32H: Non-existent data address) is returned (error).

Header (3AH)	Slave address (30H 31H)	Function code (38H 33H)	Exception code [02H] (30H 32H)	Error check LRC (37H 41H)	Delimiter CR+LF (0DH 0AH)
-----------------	----------------------------	----------------------------	--------------------------------------	------------------------------	---------------------------------

③ **Setting (Address 1, SV)** [When setting SV to 600°C (0258H)]

- A request message from the master

Header (3AH)	Slave address (30H 31H)	Function code (30H 36H)	Data item [0001H] (30H 30H 30H 31H)	Number of data [0258H] (30H 32H 35H 38H)	Error check LRC (39H 45H)	Delimiter CR+LF (0DH 0AH)
-----------------	----------------------------	----------------------------	---	--	------------------------------	---------------------------------

- Response message from the slave in normal status

Header (3AH)	Slave address (30H 31H)	Function code (30H 36H)	Data item [0001H] (30H 30H 30H 31H)	Data [0258H] (30H 32H 35H 38H)	Error check LRC (39H 45H)	Delimiter CR+LF (0DH 0AH)
-----------------	----------------------------	----------------------------	---	--------------------------------------	------------------------------	---------------------------------

- Response message from the slave in exception (error) status (When a value out of the setting range is set)
The function code MSB is set to 1 for the response message in exception (error) status [86H (38H 36H)].
The exception code 03H (30H 33H: Value out of the setting range) is returned (error).

Header (3AH)	Slave address (30H 31H)	Function code (38H 36H)	Exception code [03H] (30H 33H)	Error check LRC (37H 36H)	Delimiter CR+LF (0DH 0AH)
-----------------	----------------------------	----------------------------	--------------------------------------	------------------------------	---------------------------------

6.3 RTU mode

8-bit binary data in command is transmitted as it is.

Data format Start bit : 1 bit

Data bit : 8 bits

Parity : No parity (Even, Odd) Selectable

Stop bit : 1 bit (2 bits) Selectable

Error detection : CRC-16 (Cyclic Redundancy Check)

Data interval : 3.5 character transmission times or less

To transmit continuously, an interval between characters which consist of one message, must be within 3.5 character transmission times.

(1) Message configuration

RTU mode is configured to start after idle time is processed for more than 3.5 character transmissions and end after idle time is processed for more than 3.5 character transmissions.

3.5 idle characters	Slave address	Function Code	Data	Error check CRC-16	3.5 idle characters
---------------------	---------------	---------------	------	--------------------	---------------------

Slave address

Slave address is an individual instrument number on the slave side and is set within the range 0 to 95 (00H to 5FH).

The master identifies slaves by the slave address of the requested message.

The slave informs the master which slave is responding to the master by placing its own address in the response message.

Slave address 0 (00H, broadcast address) can identify all the slaves connected. However slaves do not respond.

Function code

The function code is the command code for the slave to undertake the following action types.

Function code	Contents
03 (03H)	Reading the set value and information from slaves
06 (06H)	Setting to slaves

Function code is used to discern whether the response is normal (acknowledgement) or if any error (negative acknowledgement) has occurred when the slave returns the response message to the master.

When acknowledgement is returned, the slave simply returns the original function code.

When negative acknowledgement is returned, the MSB of the original function code is set as 1 for the response.

For example, when the master sends request message setting 10H to the function code by mistake, slave returns 90H by setting the MSB to 1, because the former is an illegal function.

For negative acknowledgement, the exception codes below are set to the data of the response messages and returned to the master in order to inform it of what kind of error has occurred.

Exception code	Contents
1 (01H)	Illegal function (Non-existent function)
2 (02H)	Illegal data address (Non-existent data address)
3 (03H)	Illegal data value (Value out of the setting range)
17 (11H)	Shinko error code 4 (Unsettable status, e.g. AT is performing)
18 (12H)	Shinko error code 5 (During setting mode by keypad operation)

Data

Data differs depending on the function code.

A request message from the master side is composed of data item, number of data and setting data.

A response message from the slave side is composed of a number of byte, data and exception codes in negative acknowledgements.

The number of data to be dealt with in one message is "1". Therefore the number of data is fixed as (0001H).

The number of response byte is (02H).

Effective range of data is -32768 to 32767 (8000H to 7FFFH).

Error check: 16 bit data to detect communication errors. Refer to "(2) Error check of RTU mode" below.

(2) Error check of RTU mode

After calculating CRC-16 (Cyclic Redundancy Check) from the slave address to the end of data, the calculated 16-bit data is appended to the end of message in sequence from low order to high order.

How to calculate CRC

In the CRC system, the information is divided by the polynomial series. The remainder is added to the end of the information and transmitted. The generation of polynomial series is as follows.

(Generation of polynomial series: $X^{16} + X^{15} + X^2 + 1$)

- ① Initialize the CRC-16 data (assumed as X) (FFFFH).
- ② Calculate exclusive OR (XOR) with the 1st data and X. This is assumed as X.
- ③ Shift X one bit to the right. This is assumed as X.
- ④ When a carry is generated as a result of the shift, XOR is calculated by X of ③ and the fixed value (A001H). This is assumed as X. If a carry is not generated, go to step ⑤.
- ⑤ Repeat steps ③ and ④ until shifting 8 times.
- ⑥ XOR is calculated with the next data and X. This is assumed as X.
- ⑦ Repeat steps ③ to ⑤.
- ⑧ Repeat steps ③ to ⑤ up to the last data.
- ⑨ Set X as CRC-16 to the end of message in sequence from low order to high order.

(3) Message example of RTU mode

① Reading (Address 1, PV)

- A request message from the master

The number of data means the data item to be read, and it is fixed as 1 (0001H).

3.5 idle characters	Slave address (01H)	Function code (03H)	Data item (0080H)	Number of data (0001H)	Error check CRC-16 (85E2H)	3.5 idle characters
---------------------	---------------------	---------------------	-------------------	------------------------	----------------------------	---------------------

- Response message from the slave in normal status [When PV=600°C (0258H)]

The number of response byte means the number of byte of the data which has been read, and it is fixed as 2 (02H).

3.5 idle characters	Slave address (01H)	Function code (03H)	Number of response byte (02H)	Number of data (0258H)	Error check CRC-16 (B8DEH)	3.5 idle characters
---------------------	---------------------	---------------------	-------------------------------	------------------------	----------------------------	---------------------

② Reading (Address 1, SV)

- A request message from the master

The number of data means the data item to be read, and it is fixed as 1 (0001H).

3.5 idle characters	Slave address (01H)	Function code (03H)	Data item (0001H)	Number of data (0001H)	Error check CRC-16 (D5CAH)	3.5 idle characters
---------------------	---------------------	---------------------	-------------------	------------------------	----------------------------	---------------------

- Response message from the slave in normal status [When SV=600°C (0258H)]

The number of response byte means the number of byte of the data which has been read, and it is fixed as 2 (02H).

3.5 idle characters	Slave address (01H)	Function code (03H)	Number of response byte (02H)	Number of data (0258H)	Error check CRC-16 (B8DEH)	3.5 idle characters
---------------------	---------------------	---------------------	-------------------------------	------------------------	----------------------------	---------------------

- Response message from the slave in exception (error) status (When data item is mistaken)
The function code MSB is set to 1 for the response message in exception (error) status (83H).
The exception code (02H: Non-existent data address) is returned (error).

3.5 idle characters	Slave address (01H)	Function code (83H)	Exception code (02H)	Error check CRC-16 (C0F1H)	3.5 idle characters
---------------------	---------------------	---------------------	----------------------	----------------------------	---------------------

③ Setting (Address 1, SV) [When setting SV to 600°C (0258H)]

- A request message from the master

3.5 idle characters	Slave address (01H)	Function code (06H)	Data item (0001H)	Number of data (0258H)	Error check CRC-16 (D890H)	3.5 idle characters
---------------------	---------------------	---------------------	-------------------	------------------------	----------------------------	---------------------

- Response message from the slave in normal status

3.5 idle characters	Slave address (01H)	Function code (06H)	Data item (0001H)	Number of data (0258H)	Error check CRC-16 (D890H)	3.5 idle characters
---------------------	---------------------	---------------------	-------------------	------------------------	----------------------------	---------------------

- Response message from the slave in exception (error) status (When a value out of the setting range is set)
The function code MSB is set to 1 for the response message in exception (error) status (86H).
The exception code (03H: Value out of the setting range) is returned (error).

3.5 idle characters	Slave address (01H)	Function code (86H)	Exception code (03H)	Error check CRC-16 (0261H)	3.5 idle characters
---------------------	---------------------	---------------------	----------------------	----------------------------	---------------------

7. Communication command table

● Data

Note on setting, reading command

- The data (set value, decimal) is converted to hexadecimal figures. A negative number is represented by 2's complement.
- When connecting plural slaves, the address (instrument number) must not be duplicated.

Setting command

- Setting range of each item is the same as that of keypad operation.
- When the data (set value) has a decimal point, a whole number (hexadecimal) without a decimal point is used.
- If the alarm type is changed during Alarm 1 type selection (0023H) and Alarm 2 type selection (0024H), the alarm value will revert to "0". Also alarm output status will be initialized.
- It is possible to set the set value with the setting command of the communication function even when the set value is locked.
- Although the options are not applied, setting the items for the options is possible using the setting command. However, they will not function.
- The instrument numbers and communication speed of the slave cannot be set by communication function.
- When sending a command by Global address [95 (7FH)], the same command is sent to all the slaves connected. However, the response is not returned.
- The memory can store up to 1,000,000 (one million) entries.
If the number of settings exceeds the limit, the data will not be saved. So frequent transmission via communication is not recommended.

Reading command

- When the data (set value) has a decimal point, a whole number (hexadecimal) without a decimal point is used for a response.

● Negative acknowledgement

The slave will return Error code 1 (31H) (Shinko protocol) or Exception code 1 (01H) (Modbus protocol) in the following cases.

- If control output OUT/OFF function (0037H) is selected after selecting Auto/Manual control function during OUT/OFF key function selection.
- If Auto/Manual control (0038H) is selected after selecting control output OUT/OFF function during OUT/OFF key function selection.
- When Manual control MV (0039H) is set during automatic control.
- When Auto-tuning/Auto-reset (0003H) is selected during PI action or ON/OFF action.

The slave will return Error code 4 (34H) (Shinko protocol) or Exception code 17 (11H) (Modbus protocol) in the following cases.

- If "Cancel (0000H)" of Auto-tuning/Auto-reset (0003H) is selected while Auto-tuning/Auto-reset is being cancelled.
- When "Perform (0001H)" of Auto-tuning/Auto-reset (0003H) is selected while Auto-tuning/Auto-reset is performing

Shinko Command type	Modbus Function code	Data item		Data
20H/50H	03H/06H	0001H	SV	Set value, Decimal point ignored
20H/50H	03H/06H	0003H	Auto-tuning/Auto-reset	0000H: Cancel 0001H: Perform
20H/50H	03H/06H	0004H	OUT1 proportional band	Set value, Decimal point ignored
20H/50H	03H/06H	0005H	OUT2 proportional band	Set value, Decimal point ignored
20H/50H	03H/06H	0006H	Integral time	Set value
20H/50H	03H/06H	0007H	Derivative time	Set value
20H/50H	03H/06H	0008H	OUT1 proportional cycle	Set value
20H/50H	03H/06H	0009H	OUT2 proportional cycle	Set value
20H/50H	03H/06H	000BH	Alarm 1 value	Set value, Decimal point ignored
20H/50H	03H/06H	000CH	Alarm 2 value	Set value, Decimal point ignored
20H/50H	03H/06H	000FH	Heater burnout alarm value	Set value, Decimal point ignored
20H/50H	03H/06H	0012H	Set value lock	0000H: Unlock 0001H: Lock 1 0002H: Lock 2 0003H: Lock 3
20H/50H	03H/06H	0015H	Sensor correction	Set value, Decimal point ignored
20H/50H	03H/06H	0016H	Overlap/Dead band	Set value
20H/50H	03H/06H	0018H	Scaling high limit	Set value, Decimal point ignored
20H/50H	03H/06H	0019H	Scaling low limit	Set value, Decimal point ignored
20H/50H	03H/06H	001AH	Decimal point place	0000H: xxxx 0001H: xxx.x 0002H: xx.xx 0003H: x.xxx
20H/50H	03H/06H	001BH	PV filter time constant	Set value, Decimal point ignored
20H/50H	03H/06H	001CH	OUT1 high limit	Set value
20H/50H	03H/06H	001DH	OUT1 low limit	Set value
20H/50H	03H/06H	001EH	OUT1 ON/OFF action hysteresis	Set value, Decimal point ignored
20H/50H	03H/06H	001FH	OUT2 action mode	0000H: Air cooling 0001H: Oil cooling 0002H: Water cooling
20H/50H	03H/06H	0020H	OUT2 high limit	Set value
20H/50H	03H/06H	0021H	OUT2 low limit	Set value
20H/50H	03H/06H	0022H	OUT2 ON/OFF action hysteresis	Set value, Decimal point ignored
20H/50H	03H/06H	0023H	Alarm 1 type	0000H: No alarm action 0001H: High limit alarm 0002H: Low limit alarm 0003H: High/Low limits alarm 0004H: H/L limit range alarm 0005H: Process high alarm 0006H: Process low alarm 0007H: High alarm with standby 0008H: Low alarm with standby 0009H: H/L limits with standby
20H/50H	03H/06H	0024H	Alarm 2 type	The same as the Alarm 1 type
20H/50H	03H/06H	0025H	Alarm 1 hysteresis	Set value, Decimal point ignored
20H/50H	03H/06H	0026H	Alarm 2 hysteresis	Set value, Decimal point ignored
20H/50H	03H/06H	0029H	Alarm 1 action delayed timer	Set value
20H/50H	03H/06H	002AH	Alarm 2 action delayed timer	Set value
20H/50H	03H/06H	0032H	Indication selection when output OFF	0000H: OFF indication 0001H: No indication 0002H: PV indication 0003H: PV+ Alarm action

Shinko Command type	Modbus Function code	Data item		Data
20H/50H	03H/06H	0033H	SV rise rate	Set value, Decimal point ignored
20H/50H	03H/06H	0034H	SV fall rate	Set value, Decimal point ignored
20H/50H	03H/06H	0037H	Control output OUT/OFF	0000H: Control output ON 0001H: Control output OFF
20H/50H	03H/06H	0038H	Auto/Manual control	0000H: Automatic control 0001H: Manual control
20H/50H	03H/06H	0039H	Manual control MV	Set value
20H/50H	03H/06H	0040H	Alarm 1 Energized/Deenergized	0000H: Energized 0001H: Deenergized
20H/50H	03H/06H	0041H	Alarm 2 Energized/Deenergized	0000H: Energized 0001H: Deenergized
20H/50H	03H/06H	0044H	Input type	0000H: K -200 to 1370°C 0001H: K -200.0 to 400.0°C 0002H: J -200 to 1000°C 0003H: R 0 to 1760°C 0004H: S 0 to 1760°C 0005H: B 0 to 1820°C 0006H: E -200 to 800°C 0007H: T -200.0 to 400.0°C 0008H: N -200 to 1300°C 0009H: PL-Ⅱ 0 to 1390°C 000AH: C(W/Re5-26) 0 to 2315°C 000BH: Pt100 -200.0 to 850.0°C 000CH: JPt100 -200.0 to 500.0°C 000DH: Pt100 -200 to 850°C 000EH: JPt100 -200 to 500°C 000FH: K -320 to 2500°F 0010H: K -320.0 to 750.0°F 0011H: J -320 to 1800°F 0012H: R 0 to 3200°F 0013H: S 0 to 3200°F 0014H: B 0 to 3300°F 0015H: E -320 to 1500°F 0016H: T -320.0 to 750.0°F 0017H: N -320 to 2300°F 0018H: PL-Ⅱ 0 to 2500°F 0019H: C(W/Re5-26) 0 to 4200°F 001AH: Pt100 -320.0 to 1500.0°F 001BH: JPt100 -320.0 to 900.0°F 001CH: Pt100 -320 to 1500°F 001DH: JPt100 -320 to 900°F 001EH: 4 to 20mA -2000 to 10000 001FH: 0 to 20mA -2000 to 10000 0020H: 0 to 1V -2000 to 10000 0021H: 0 to 5V -2000 to 10000 0022H: 1 to 5V -2000 to 10000 0023H: 0 to 10V -2000 to 10000
20H/50H	03H/06H	0045H	Direct/Reverse action	0000H: Reverse action 0001H: Direct action
20H/50H	03H/06H	0047H	AT bias	Set value
20H/50H	03H/06H	0048H	ARW	Set value
20H/50H	03H/06H	0049H	Heater burnout alarm 2 value	Set value, Decimal point ignored.

Shinko Command type	Modbus Function code	Data item		Data
20H/50H	03H/06H	004AH	OUT1 rate of change limit	Set value
20H/50H	03H/06H	0050H	Backlight	0000H: All are backlit 0001H: Only PV display is backlit 0002H: Only SV display is backlit 0003H: Only Action indicators are backlit 0004H: PV+SV displays are backlit 0005H: PV+ Action indicators are backlit 0006H: SV+ Action indicators are backlit
20H/50H	03H/06H	0051H	PV color	0000H: Green 0001H: Red 0002H: Orange 0003H: Alarm ON: Green→Red 0004H: Alarm ON: Orange→Red 0005H: PV continuous change 0006H: PV continuous change + Alarm ON; Red
20H/50H	03H/06H	0052H	PV color range	Set value, Decimal point ignored.
20H/50H	03H/06H	0053H	Backlight time	Set value
50H	06H	0070H	Key operation change flag clearing	0000H: No action 0001H: All clearing
20H	03H	0080H	PV (process variable)	Decimal point ignored
20H	03H	0081H	OUT1 MV	Decimal point ignored
20H	03H	0082H	OUT2 MV	Decimal point ignored
20H	03H	0083H	SV(When SV rises or falls)	Decimal point ignored
20H	03H	0085H	Status flag	<p>0000 0000 0000 0000</p> <ul style="list-style-type: none"> 2⁰: OUT1 0: OFF, 1: ON (DC current output: Not fixed) 2¹: OUT2 0: OFF, 1: ON 2²: Alarm 1 output 0: OFF, 1: ON 2³: Alarm 2 output 0: OFF, 1: ON 2⁴: Not used, Always 0 2⁵: Not used, Always 0 2⁶: Heater burnout alarm 0: OFF, 1: ON (When Sensor burnout 0: OFF) 2⁷: Not used, Always 0 2⁸: Overscale 0: OFF, 1: ON 2⁹: Underscale 0: OFF, 1: ON 2¹⁰: Control output OUT/OFF selection 0: ON, 1: OFF 2¹¹: During Auto-tuning/Auto-reset 0: OFF, 1: During Auto-tuning/Auto-reset 2¹²: OUT/OFF key function selection 0: OUT/OFF function, 1: Auto/Manual control 2¹³: Not used, always 0 2¹⁴: Auto/Manual control 0: Automatic control, 1: Manual control 2¹⁵: Change in key operation 0: No, 1: Yes
20H	03H	0086H	CT1 current value	Decimal point ignored
20H	03H	0087H	CT2 current value	Decimal point ignored

Shinko Command type	Modbus Function code	Data item		Data
20H	03H	00A1H	Unit specification flag	
			0000 0000 0000 0000	
				2 ⁰ : Set value memory external selection 0: Not added, 1: Added
				2 ¹ : Serial communication 0: Not added, 1: Added
				2 ² : Heater burnout alarm 0: Not added, 1: Added
				2 ³ : Heater burnout alarm rating 0: 20A, 1: 50A
				2 ⁴ : Heater burnout alarm specification 0: Single phase, 1: 3-phase
				2 ⁵ : Alarm 2 output 0: Not added, 1: Added
				2 ⁶ : Heating/Cooling control output 0: Not added, 1: Added
				2 ⁷ to 2 ¹⁵ : Not used, always 0

● Notes on programming monitoring software

How to speed up the scan time

When monitoring plural units of ACS-13A, set the program so that requisite minimum pieces of data such as PV (0080H), OUT1 MV (0081H), status flag (0085H), etc. can be read, and for other data, set the program so that they can be read only when their set value has changed. This will speed up the scan time.

How to read the set value change by the front keypad operation

If any set value is changed by the keypad operation, the ACS-13A sets the [Status flag (0085H) 2¹⁵: Change in key operation] to [Yes (1)].

There are 2 methods of reading the set value change by the front keypad as follows.

Reading method 1

- (1) On the software side, check that [Status flag (0085H) 2¹⁵: Change in key operation] has been set to [Yes (1)], then read all set values.
- (2) Clear the [Status flag (0085H) 2¹⁵: Change in key operation], by setting the [Key operation change flag clearing (0070H)] to [All clearing (0001H)].

If [Key operation change flag clearing (0070H)] is set to [All clearing (0001H)] during the setting mode of the ACS-13A, Error code 5 (35H, Shinko protocol) or Exception Code 18 (12H, Modbus protocol) will be returned as a negative acknowledgement. And [Status flag (0085H) 2¹⁵: Change in key operation] cannot be cleared. Set a program so that all set values can be read until acknowledgement is returned.

Reading method 2

- (1) On the software side, check that [Status flag (0085H) 2¹⁵: Change in key operation] has been set to [Yes (1)], then set the [Key operation change flag clearing (0070H)] to [All clearing (0001H)].
- (2) Set the program depending on the acknowledgement or negative acknowledgement as follows.

When acknowledgement is returned;

Consider it as settings completed, and read all set values.

When Error code 5 (35H, Shinko protocol) or Exception code 18 (12H, Modbus protocol) is returned as a negative acknowledgement;

Consider it as during setting mode, and read the requisite minimum pieces of data such as PV (0080H), OUT1 MV (0081H), status flag (0085H), etc. then return to step (1).

Thus, programs which do not affect the scan time can be created using the methods described above, even if set values on the monitoring software will not be updated until settings are complete.

How to read PID parameters after auto-tuning finishes

The ACS-13A sets [Status flag (0085H) 2¹¹: During Auto-tuning/Auto-reset] to [During Auto-tuning/Auto-reset (1)] while auto-tuning is performing. After auto-tuning is finished, PID parameters are updated.

On the software side, read the parameters such as P, I, D, ARW after checking that [Status flag (0085H) 2¹¹: During Auto-tuning/Auto-reset] has been set to [OFF (0)].

Note when sending all set values at one time

- If alarm type is changed during Alarm 1 type selection (0023H) and Alarm 2 type selection (0024H), alarm value will revert to "0". First, send the selected alarm type, then send the alarm value.
- If input type is selected during Input type selection (0044H), set values such as SV, OUT1 proportional band, Alarm 1 value, etc. will be initialized. First, send the selected input type, then send other set values.

When communicating with a PLC

Command example (Shinko protocol) when communicating with a Mitsubishi PLC (FX series, etc.)

• Reading (Top D register: D100)

Address 1, PV reading

Sending Data (STX)!() () (0)(0)(8)(0)(D)(7)(ETX)			
Command		Register	Code
Header (STX)	02H	D100(LSB)	02H
Address	1	D100(MSB)	21H
Sub address	20H	D101(LSB)	20H
Command type	20H	D101(MSB)	20H
Data item	&H80	D102(LSB)	30H
		D102(MSB)	30H
		D103(LSB)	38H
		D103(MSB)	30H
Checksum		D104(LSB)	44H
		D104(MSB)	37H
Delimiter (ETX)	03H	D105(LSB)	03H

Communication setting [MOVP H0C86 D8120]

Reading + Setting [RS D100 K11 D108 K26]

Reading only [RS D100 K11 D106 K26]

- 1 [MOV H2102 D100]
- 2 [MOV H2020 D101]
- 3 [MOV H3030 D102]
- 4 [MOV H3038 D103]
- 5 [MOV H3744 D104]
- 6 [MOV H03 D105]

• Setting (Top D register: D120)

Address 1, SV setting [When setting SV to 600°C (0258H)]

Sending Data (STX)!() (P)(0)(0)(0)(1)(0)(2)(5)(8)(D)(F)(ETX)			
Command		Register	Code
Header (STX)	02H	D120(LSB)	02H
Address	1	D120(MSB)	21H
Sub address	20H	D121(LSB)	20H
Command type	P	D121(MSB)	50H
Data item	&H1	D122(LSB)	30H
		D122(MSB)	30H
		D123(LSB)	30H
		D123(MSB)	31H
Data item	600	D124(LSB)	30H
		D124(MSB)	32H
		D125(LSB)	35H
		D125(MSB)	38H
Checksum		D126(LSB)	44H
		D126(MSB)	46H
Delimiter (ETX)	03H	D127(LSB)	03H

Reading + Setting [RS D120 K15 D128 K26]

Reading only [RS D120 K15 D128 K22]

- 1 [MOV H2102 D120]
- 2 [MOV H5020 D121]
- 3 [MOV H3030 D122]
- 4 [MOV H3130 D123]
- 5 [MOV H3230 D124]
- 6 [MOV H3835 D125]
- 7 [MOV H4644 D126]
- 8 [MOV H03 D127]

8. Set value digital transmission

By connecting to Shinko programmable controllers [PC-900, PCD-33A with options SVTC (set value digital transmission)], set values can be received from the programmable controllers.

8.1 Wiring

For Set value digital transmission, connect YA(-) with YA(-), YB(+) with YB(+), SG with SG terminals respectively in the same way as the Serial communication (RS-485).

Up to 31 units of the ACS-13A can be connected.

The following shows connection example of PCD-33A and ACS-13A units.

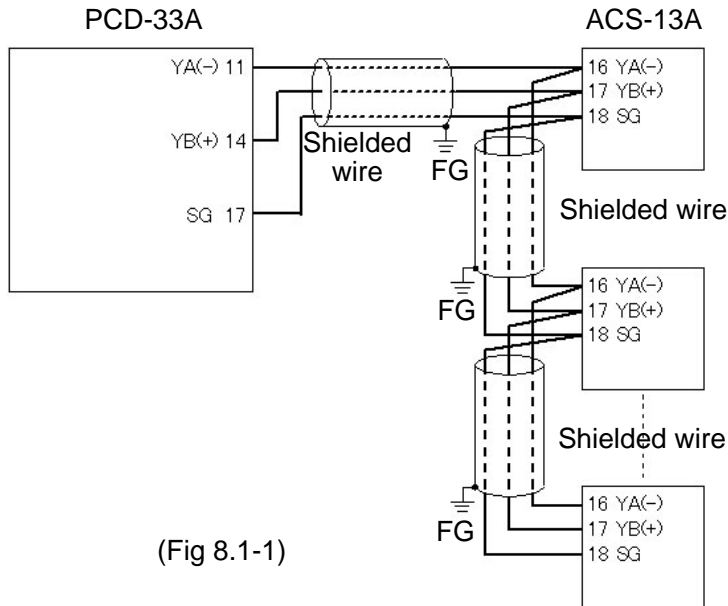

(Fig 8.1-1)

8.2 Setting method of the programmable controller (PCD-33A) and ACS-13A

(1) Setting the PCD-33A

If SVTC option is added to the PCD-33A, none of setting is required.

Check that Set value digital transmission (LBI) is selected during Communication protocol selection (C7L) in Auxiliary function setting mode 1.

(2) Setting the ACS-13A

Check the following items in the Auxiliary function setting mode. (Refer to Chapter "3. Communication parameter setting".)

- (a) Shinko protocol has been selected during Communication protocol selection
- (b) Communication speed of the ACS-13A is equal to that of the PCD-33A.

(3) Starting Set value digital transmission

Input the program set values to the PCD-33A.

If the program is executed by pressing the RUN key, set values of the PCD-33A will be sent to the ACS-13A.

During program standby, "0" will be sent to the ACS-13A.

9. Specifications

- Cable length : Max. communication distance 1.2km
Cable resistance: Within 50Ω (Terminator is not necessary or 120Ω or more on one side.)
- Communication interface: EIA RS-485
- Communication method : Half-duplex communication
- Communication speed : 2400/4800/9600/19200bps (Selectable by keypad) (Default: 9600bps)
- Synchronization : Start-stop synchronization
- Code form : ASCII, binary
- Data bit/Parity : 7 bits, 8bits/Even, Odd and No parity (Selectable by keypad) (Default: 7 bits/Even parity)
- Stop bit : 1, 2 (Selectable by keypad) (Default: 1)
- Communication protocol: Shinko protocol/ Modbus ASCII/ Modbus RTU (Selectable by keypad) (Default: Shinko protocol)
- Data format

Communication protocol	Shinko protocol	Modbus ASCII	Modbus RTU
Start bit	1	1	1
Data bit	7	7 or 8	8
Parity	Yes (Even)	Yes (Even, Odd) No parity	Yes (Even, Odd) No parity
Stop bit	1	1 or 2	1 or 2

Number of connectable units: Maximum 31 units to 1 host computer

Error correction : Command request repeat system

Communication error detection: Parity, checksum(Shinko protocol), LRC(Modbus ASCII), CRC-16(Modbus RTU)

Digital external setting : Receives digital set values from Shinko programmable controllers (PC-900, PCD-33A with the SVTC option)

10. Troubleshooting

If any malfunctions occur, refer to the following items after checking the power supply to the master and the slave.

- **Problem: Communication failure**

Check the following
Make sure that communication connector is securely connected.
Check that wiring of the communication connector is correct. Refer to "2. Wiring".
Burnout or imperfect contact on the communication cable and the connector.
Communication speed of the slave does not coincide with that of the master. Refer to "3. Communication parameter setting".
The data bit, parity and stop bit of the master do not accord with those of the slave. Refer to "3. Communication parameter setting".
The instrument number (address) of the slave does not coincide with that of the command. Refer to "3. Communication parameter setting".
The instrument numbers (addresses) are duplicated in multiple slaves. Refer to "3. Communication parameter setting".
Make sure that the program is appropriate for the transmission timing. Refer to "4. Communication procedure".

- **Problem: Although communication is occurring, the response is 'NAK'.**

Check the following
Check that a non-existent command code has not been sent.
The setting command data exceeds the setting range of the slave.
The controller cannot be set when functions such as AT is performing.
The ACS-13A is in the front keypad operation setting mode.

For all other malfunctions, please contact our main office or dealers.

SHINKO TECHNOS CO., LTD. OVERSEAS DIVISION

Reg. Office: 2-5-1, Senbahigashi, Minoo, Osaka, Japan

URL : <http://www.shinko-technos.co.jp>

E-mail : overseas@shinko-technos.co.jp

Tel : 81-72-727-6100

Fax: 81-72-727-7006