



Product sheet

ATS400 machinery tester

Product Images



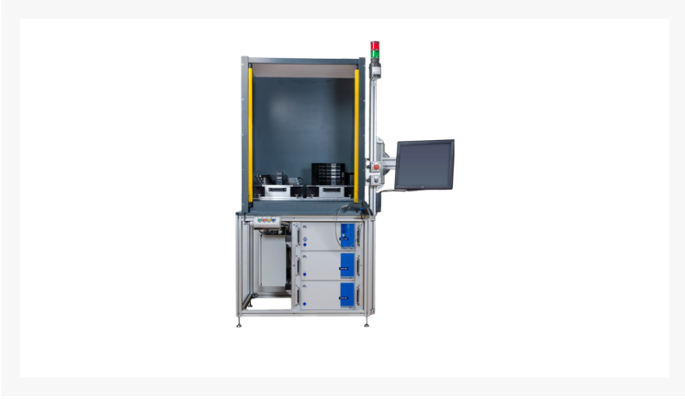

Standard X2



Standard X4/X5



Standard X6/X8

Additional Information

Article number	201903
HV AC - High Voltage Testing	100,0 - 5000 V AC, 0,01 - 100,00 mA (opt. from 1 nA), potential free, ramp, discharge monitoring
ISO - Insulation Testing	50,0 - 1000 V DC, 500,0 k Ω - 400,0 M Ω (opt. 10 G Ω), current limited accor. EN 50191, earthed on one side, active discharge, ramp, discharge monitoring
PE - Testing of Protective Earth	2,0 - 25,0 A AC/DC (opt. up to 40 A), 1 - 500 m Ω , 6 - 12 V, 4 - wire measurement
Outer Dimensions (W x H x D)	Short Case: 400 x 210 x 446 mm
Contacting options	CCG

Short Description

- For efficient and safe testing of machines and control cabinets
- Test mode with predefined test points and operating instructions
- Multi-test mode for variable test points
- Greater safety in the testing process thanks to test pistols with automatic start function: Test pistols remain voltage-free until safe contact is established; when removed, the voltage drops immediately
- Efficient protective conductor testing using a handheld test probe for all relevant contact points
- 5 different versions available
- LAN, USB, RS232, CAN, VGA, DIGITAL-IN/OUT, Analog-IN/OUT, PROFINET RT, Frequency-IO (depending on the user interface)
- Extension modules: matrix, AC- and DC-sources, hot HV, contact units for test object, ...
- CE compliant, standard safety technology as required in BS/EN 50191, only system with TÜV-certified safety circuit up to PLe

Additional output: **PEP4-socket**

- PE-connection for mains terminal of the test object, this enables completely independent PE-testing, separated from HV- ISO-testing.

Description



**INTEGRATED
SAFETY CIRCUIT**
TÜV-certified
(PLe, SIL3, Cat4, IIIc)



**INTUITIVE
USABILITY**
and perfect
data management



**2-CHANNEL OSCILLOSCOPE
FUNCTION**
High-resolution visualization
of the measurement results



**LEADING IN
ACCURACY**
Metrology and
Calibration Capability



HIGH AVAILABILITY
due to
common parts strategy and
all parts in stock



**RESIDUAL VOLTAGE
MONITORING**
and active discharge
of the test object



HIGH PROCESS SAFETY
through monitoring
of contacts and
minimum current



SECURITY OF INVESTMENT
through retrofittability
of additional
test modules

Operating variants



OPERATING VAR. X2

OPERATING VAR. X4

OPERATING VAR. X5

OPERATING VAR. X6

OPERATING VAR. X8

GENERAL

Typical Use Case	Remote	Stand-Alone	Stand-Alone	Stand-Alone	Stand-Alone
Remote Operation	yes	yes	yes	yes	yes
Stand Alone Operation	no	yes	yes	yes*	yes
Touch Display	—	5.7"	10.4"	—	10.4"
Operating System	—	WIN CE	WIN CE	WIN10 Pro	WIN10 Pro
On Board DataView3	no	yes	yes	yes	yes
Remote maintenance	no	no	no	yes	yes

CONNECTORS/INTERFACES

Safety Circuit (PLe, SIL3, Cat4)	yes	yes	yes	yes	yes
Signal lights	yes	yes	yes	yes	yes
Ethernet LAN	no	optional	100 Mbit/s	1 Gbit/s	1 Gbit/s
Profinet	optional	optional	optional	no	no
RS232	yes	yes	yes	yes	yes
CAN (for external extensions)	yes	yes	yes	yes	yes
ETL-IO (digital remote control)	no	yes	yes	yes	yes
Digital-IO	optional	optional	optional	optional	optional
Analog-IO	optional	optional	optional	optional	optional
VGA	no	no	no	yes	yes
HDMI	no	no	no	2 x	2 x
USB 2.0	no	optional	yes	2 x	2 x
USB 3.0	no	no	no	2 x	2 x
PS/2	no	no	no	yes	yes

CONTROL OPTIONS

.NET	yes	yes	yes	yes	yes
ASCII	yes	yes	yes	yes	yes
DLL	yes	yes	yes	yes	yes

EXTENSIONS

Printer	no	no	no	yes	yes
Barcode reader	no	optional	yes	yes	yes

* with external monitor

Technical specifications

High Voltage Testing HV-AC 5 000 V AC - 100 mA:

Test Voltage:

Range:	100 - 5 000 V AC
Resolution, digit:	10 V
Measurement uncertainty:	1 % of measured value +/- 2 digits
Output frequency:	45.0 – 65.0 Hz, resolution 0.1 Hz
Waveform:	Sinusoidal according to EN 61180, electronically generated
Voltage stability:	Output electronically regulated (PI-controller)
Maximum output power:	> 500 VA, including active DUT discharge
Test voltage switching:	Test voltage is switched at zero voltage crossing
Ramp function:	Freely programmable from 0.2 s up to 6 000 s, including start voltage

Test Current:

Maximum trip current:	0.1 – 100.0 mA
Minimal trip current:	0.0 – 100.0 mA
Resolution:	0.1 mA
Measurement uncertainty:	1 % of measured value +/- 3 digits
Short circuit current:	> 200 mA

Test Time:

Range:	0.5 s – 6 000 s, longer test time optional available
Ramptime range	0.2 s – 6 000 s
Resolution:	0.1 s
Measurement uncertainty:	+/-10 ms
Start of test time:	The test time will only be started if the set test voltage is reached

Other:

Error detection:	Limit Detection, Peak Detection and Arc Detection
Current and voltage measurement:	Directly at high voltage potential
Contact monitoring *:	The contact to the DUT is monitored when using a suitable contacting unit (4-pole)
Test lead break monitoring *:	Monitoring of the test lead if there is a cable break
Test pistol start automatic *:	The test can be started by contacting the DUT with the test pistols

Earthing:

Potential free and suitable for test pistol operation according to EN 50191

* Patents: DE: 100 11 466.0 und 100 11 345.1, EU: 01 105 568.8 und 01 105 567.0

Insulation Testing ISO-DC 1 000 V DC - 400 MΩ, safety current limited

Test Voltage:

Range:	50 - 1 000 V DC
Resolution, digit:	1 V
Measurement uncertainty, accuracy:	1 % of measured value +/- 5 digits
DC voltage:	electronically generated
Voltage stability:	output voltage electronically regulated, PI controller
Voltage control:	fully electronic, including active DUT discharge and discharge monitoring
Ramp function:	freely programmable from 0.2 up to 6 000 s, including start voltage

Resistance:

Range:	0.50 - 400 MΩ
Measurement range 1:	0.50 - 1.99 MΩ (≥ 100 V DC)
Resolution, digit:	0.01 MΩ
Measurement uncertainty, accuracy:	1 % of measured value +/- 3 digits
Measurement range 2:	2.0 - 99.9 MΩ (≥ 200 V DC)
Resolution, digit:	0.1 MΩ
Measurement uncertainty, accuracy:	2 % of measured value +/- 3 digits
Measurement range 3:	100 - 400 MΩ (≥ 500 V DC)
Resolution, digit:	1 MΩ
Measurement uncertainty, accuracy:	4 % of measured value +/- 3 digits

Test Time:

Range:	0.5 s – 6 000 s, longer test time optional available
Ramptime range	0.2 s – 6 000 s
Resolution:	0.1 s
Measurement uncertainty:	+/-10 ms
Start of the test time:	The test time will only be started if the set test voltage is reached

Other:

Contact monitoring:	optional available
Test lead break monitoring:	optional available

Test pistol start automatic:	optional available
Earthing:	earthed on one side
Current limitation:	CE conformity according to EN 50191, < 12 mA

Protective Earth Testing PE-AC/DC 25 A - 500 mOhm

Resistance:

Range:	1 - 500 mΩ
Resolution, digit:	1 mΩ
Measurement uncertainty, accuracy:	1 % of measured value +/- 3 digits

Test Current:

Range:	2.0 - 25.0 A AC/DC (opt. up to 40 A)
Resolution, digit:	0.1 A
Measurement uncertainty, accuracy:	1 % of measured value +/- 3 digits
Wave form:	sinusoidal, electronically generated and regulated

Test Voltage:

Open circuit voltage:	6 - 12 V
Resolution, digit:	10 mV
Measurement uncertainty:	1 % of measured value +/- 3 digits
Resolution, digit:	1 V

Test Time:

Range:	0.5 s - 6 000 s, longer test time optional available
Resolution:	0.1 s
Measurement uncertainty:	+/-10 ms
Start of the test time:	The test time will only be started if the set test voltage is reached

Other:

4-Wire measurement:	Measurement with separated source and sense paths
Minimal test current monitoring:	If the test current drops under a set value the test will abort
Test probe with start button:	The start button on the test probe can trigger the test (the test current is only supplied when the probe is connected to the DUT)
Test probe with result LED:	The multi-colour-LED on the probe shows the result of the test (red/green)

Short Housing:

Housing dimensions:

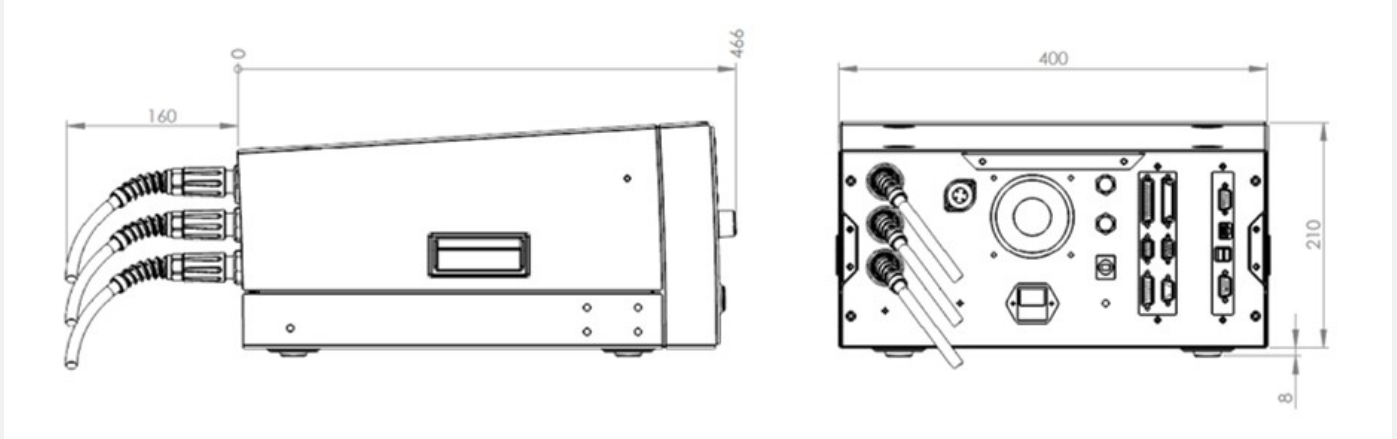

Housing dimensions with angled plugs:

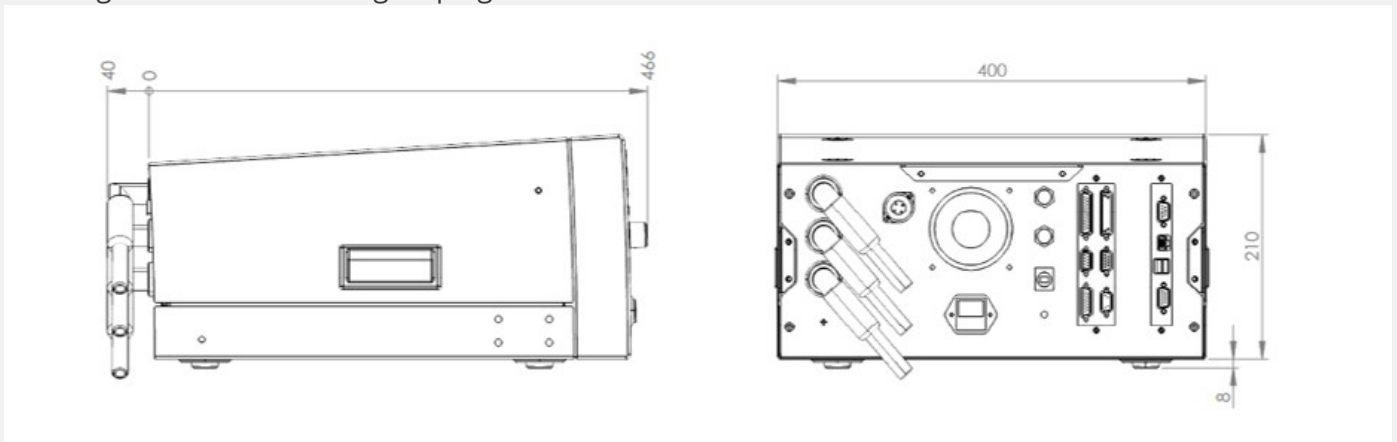

Housing dimensions with installation set 19 inches:

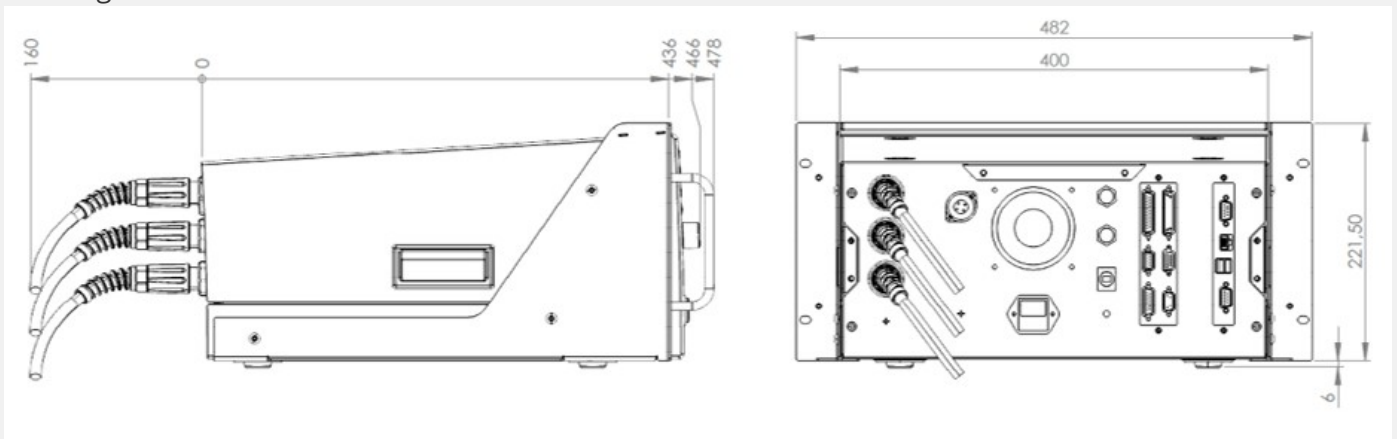

Housing dimensions with installation set 19 inches and angled plugs:

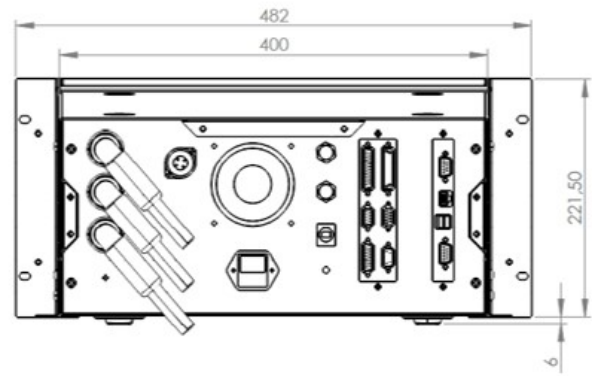
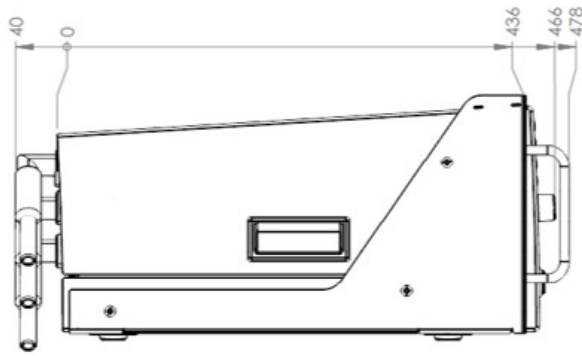

GENERAL DEVICE DATA:

Input voltage:	230 V, 50 Hz / 60 Hz
Mains connection:	Schuko plug, IEC connector C14, vertical installation, 10 A, with fuse
Tolerance input voltage:	+/- 10 %
Current consumption:	max. 10 A
Fuse:	10 A, T, 5 x 20 mm, 250 V
Display:	X2-variant: no display, remote control variant X4-variant: TFT colour display 5,7" with touch function X5-variant: TFT colour display 10,4" with touch function X6-variant: no Display, external monitor required X8-variant: TFT colour display 10,4" with touch function
Operating system user interface:	X2-variant: remote control only X4-variant: WIN CE ® X5-variant: WIN CE ® X6-variant: WINDOWS ® X8-variant: WINDOWS ®
Storage of test plans and results:	X2-variant: storage through higher-level control X4-variant: locally on SD card, optionally USB or LAN X5-variant: Optionally locally on SD-CARD, USB or LAN X6-variant: Optionally locally on SD-CARD, USB or LAN X8-variant: Optionally locally on SD-CARD, USB or LAN
Setting of the test parameters:	Manually in the individual test menu or via test plan (DataView user interface) or fully automatically via interface (ASCII, DLL, .NET)
Error signaling:	acoustically, visually and via interface
Standard equipment on delivery:	instruction manual, mains cable, safety circuit plug
Calibration:	factory calibration including calibration certificate

Casing:	DAkkS calibration optional available Metal case, RAL 7035
Weight:	depending on the modules installed, from 25 to 35 kg

Environmental conditions:

Casing:	IP20
Humidity:	max. 80 %, not condensating
Permitted temperature range:	+ 5 up to + 40 °C
Max. altitude above sea level:	2 000 m
Cooling:	active cooling

Electric safety and standards:

EN 61010-1:	Safety requirements for electrical equipment for measurement, control, and laboratory use
EN 61326-1:	Electrical equipment for measurement, control, and laboratory use - EMC requirements
EN 61000-3-3 / EN 61000-3-2:	Electromagnetic compatibility (EMC)
EN 50191:	Erection and operation of electrical test equipment
EN 60598-1:	Luminaires / Part 1: General requirements and tests
Pollution degree:	2
Protection class:	1

Advanced device setup:

User administration:	individually configurable
Signal configurator:	individual configuration of digital result outputs
Data manager for test plans and results:	individual setting of storage options, storage location, naming of the result file, and automated creation of result directories
Buzzer options:	individual configurations of acoustic signals
Basic settings of the test system:	language selection, device name, interfaces configuration
Start of the user interface:	individual setting of the desired start menu (e.g. start directly in the test plan selection menu via barcode)
Selection of test programme:	manually via selection window, process-safe via barcode or keyboard, via digital interface or by reading out a transfer file
Manager for dummy testing:	Dummy test is automatically requested according to configuration (e.g. at programme start, at user change, via digital interface, after a certain number of test objects, at a certain time or after a time interval)

Locking options for safety testing cages:	individual setting of the locking options (during the test, on good, on bad, ...)
---	---

Start Options for Testing:

Start and stop signal through test pistol *:	Special automated start in 4-wire technology. The start of the test (switching on the test voltage) only takes place when both test pistols are safely contacted (depending on the test types)
Start via safety circuit:	The test is started by locking the safety circuit
Start button on the device:	The test is started by pressing the button on the front of the device
Start via contact monitoring *:	start only when contact is made (source and sense connected) and there is no cable break - permanent monitoring
Start via serial nterface:	Start via higher-level control (PLC or PC)
Start via digital interface:	start via digital IO such as PLC, footswitch, push button, etc. ...
Start options:	individual setting of start modes

() patented:*

The ETL contact monitoring is a patented procedure:

German patents: 100 11 466.0 and 100 11 345.1

European patents: 01 105 568.8 and 01 105 567.0

Interfaces:

ETL Interface / Digital IO:	Start, stop, result GOOD, result ERROR, and test running, etc. (all digital outputs are designed with wear-free semi conductor components)
RS232 / LAN PC Interface *:	Remote control interface for customer´s own applications or for data management package ETL DataView
CAN Interface:	to expand the test system for supplementary features and further external expansion stages
LAN Interface *:	for connection to the customer´s own network, e.g. for storing test results, depending on the operating variant
USB Interface *:	for connection of further storage edia as well as keyboard and mouse, depending on operating variant
VGA connection *:	for connection of an external screen, only X6- and X8-variant

** The installed interfaces depend on the operating variant, see illustration "Operating Variants"*

Connections - Safety Components:

Signal lamps:

Connection of a signal lamp combination (green / red) according to EN 50191

Safety circuit:

With appropriate wiring, 3 different standard-compliant safety circuits can be implemented by the customer:

- Testing with test pistols
- Testing with safety testing cages / two-hand control
- Testing in an automation solution / production line

USER Interface / Digital IO, optional:

digital interface for freely programmable inputs and outputs (all digital outputs are designed with wear-free semiconductor components)

Analogue IO, optional:

4 analogue inputs for recording analogue signals (0 - 10 V DC)

2 analogue outputs (D/A), e.g. for result monitoring

Frequency IO, optional:

4 frequency inputs for detecting speeds and their direction of rotation

Device connections - for contacting the test object (Machinery tester, 201903):

2-poled HV-socket: HV1 / L1 / R1.1	DUT*: Connection L1 / Resistance
2-poled HV-socket: HV2 / PEX	DUT*: Connection PE - Mains
7-poled PE-socket: TEST PROBE / PEP7	DUT*: Connection PE - Casing
4-poled PE-socket: PEX2 / PEP4	DUT*: Connection PE - Contact Mains 2
	* <i>Device Under Test</i>



Contact details

ETL Prüftechnik GmbH
Hauptsitz / Headquarter
Lembergstraße 23

70825 Korntal-Münchingen

Irrtümer und technische Änderungen vorbehalten / Errors and technical modifications excepted.
Frühere Versionen können unter info@etl-prueftechnik.de angefragt werden / Earlier versions can be requested at info@etl-prueftechnik.de.

Version number: 4.0